

# Parking & Open Air Structures Products

## Expansion Control Systems

---

PARKING & OPEN AIR STRUCTURES JOINT SYSTEMS

EXTERIOR WALL JOINT SYSTEMS

FIRE BARRIER SYSTEMS

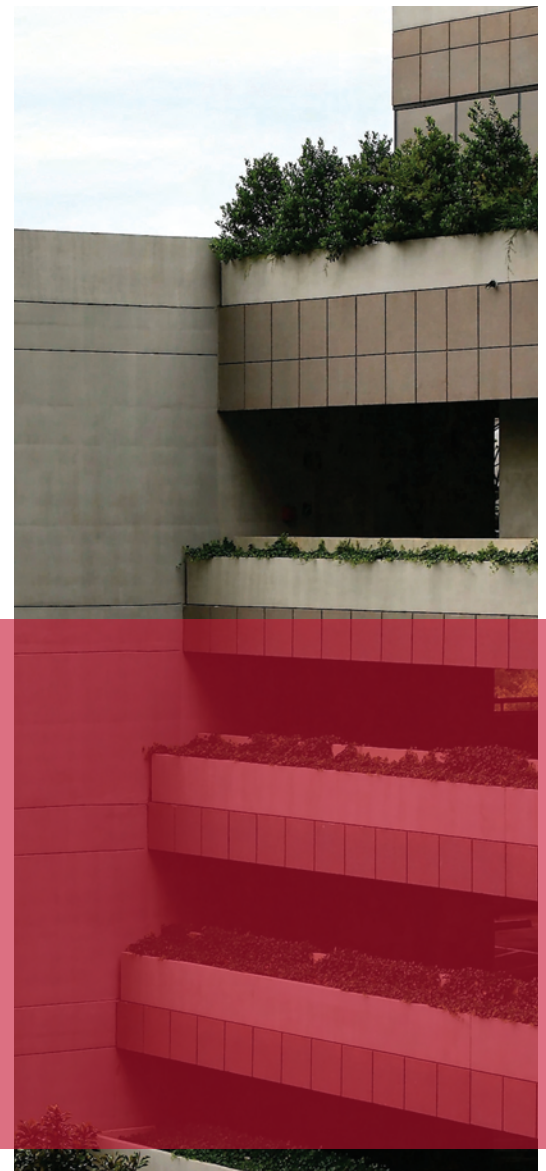

## Backed by a world leader.

The BASF Group comprises more than 160 subsidiaries and joint ventures and operates more than 150 production sites in Europe, Asia, North America, South America and Africa. BASF has customers in over 200 countries and supplies products to a wide variety of industries.

Not just a leader in its industry, BASF is a global leader in sustainability and corporate social responsibility. The company is included in the Innovest Global 100 list – among the world's most successful companies in the areas of environmental protection, social affairs and corporate governance. BASF is also listed on the Dow Jones Sustainability Index, the FTSE4Good Index and Storebrand SRI Funds.

BASF has won awards from the Sustainable Buildings Industry Council and the American Plastics Council for its Eco-Efficiency Analysis. This industry-leading sustainability measurement tool provides certified and robust quantitative analysis of both the ecological and economic impact of products over their lifecycle. Most importantly, the tool provides measurement from a customer perspective, allowing the user to observe the effects of various actions on different future scenarios.

**For additional information about our products visit our website at**

**[www.wbacorp.com](http://www.wbacorp.com)**

**WBA can develop a custom product to meet your specific application.**

**Contact WBA at 800.677.4922 for more information.**

**It's the things you don't see that make us better.**



## Industry programs that work.

### Factory Trained Applicator

The industry's first Factory Authorized Certified Applicator Program – for the installation of Parking & OAS Expansion Joint Systems and Fire Barriers. Specify Wabo® Expansion Joint Systems installed by factory trained applicators to receive product and service warranties.





Expansion & Contraction



Vertical Displacement



Expansion, Contraction & Vertical Displacement



Lateral Shear



Expansion, Contraction, Vertical Displacement & Lateral Shear



Fire Rated  
(with added fire barrier system)



Water-Resistant



Water Proof



Color Choice  
Elastomeric Seals



Available in Stainless  
Steel or Aluminum



Meets ADA Guidelines



Light Cart



Fork Truck Traffic



















Vehicle Traffic



Warnock Hersey  
Listed Product



Underwriters Laboratories  
Listed Product

	Page #	Joint Opening	Movement	
Expansion Joint Systems	 Wabo®Crete Membrane	4-5	2" - 6"	
	 Jeene®	6	Up to 5"	
	 Wabo®InverSeal	7	Up to 8.5"	
	 Wabo®SeismicSpan	8	Up to 18"	
	 Wabo®SafetyFlex	9	Up to 18"	
	 Wabo®Crete StripSeal	10	2.5" - 8"	
	 Wabo®ElastoFlex	11	1.25" - 6"	
	 Wabo®CompressionSeal	12	1" - 3.5"	
	 Wabo®StadiaFlex	13	2" - 4"	
	 Wabo®WeatherSeal II	14	Up to 5"	
	 Wabo®Seismic WeatherSeal	14	Up to 6"	
	 Wabo®GutterFlex	15	3" - 41"	
	 Wabo®UreFlex	16	Up to 2.5"	
	 Wabo®SiliconeSeal	16	Up to 3"	
	 Wabo®WaterTite	17	2.25" - 9.5"	
	 Wabo®WeatherSeam	18	2" - 24"	
	 Wabo®HSeal	19	Up to 4"	
	 Wabo®Evazote UV	19	Up to 4.83"	
	Fire Barrier	 Wabo®FlameGuard I	20	2.5" - 12"
 Wabo®FlameGuard II		21	2" - 12"	
 Wabo®ThermoShield		22	Up to 4"	
 Wabo®FireFlex		23	Up to 20"	

# Wabo®Crete Membrane



## FEATURES

- Original elastomeric header system
- Complex directional changes
- Watertight
- Continuous Elastomeric Gland
- Impact absorbing header
- ME profile is ADA compliant

### Slab-to-Slab

Model #	Installation Width				Joint Opening "A"					
	Min		Max		Min		Max		Total	
	in	mm	in	mm	in	mm	in	mm	in	mm
<b>ME-225</b>	1.00	25	2.00	51	0.75	19	2.25	57	1.50	38
<b>ME-300</b>	2.00	51	2.75	70	1.50	38	3.00	76	1.50	38
<b>ME-400</b>	2.50	64	3.75	95	1.50	38	4.00	102	2.50	64
<b>ME-500</b>	3.00	76	4.75	121	1.75	44	5.00	127	3.25	83
<b>ME-600</b>	3.50	89	5.75	146	2.00	51	6.00	152	4.00	102

### Slab-to-Wall

Model #	Installation Width				Joint Opening "A"					
	Min		Max		Min		Max		Total	
	in	mm	in	mm	in	mm	in	mm	in	mm
<b>ME-225C</b>	1.00	25	2.00	51	0.75	19	2.25	57	1.50	38
<b>ME-300C</b>	2.00	51	2.75	70	1.50	38	3.00	76	1.50	38
<b>ME-400C</b>	2.50	64	3.75	95	1.50	38	4.00	102	2.50	64
<b>ME-500C</b>	3.00	76	4.75	121	1.75	44	5.00	127	3.25	83
<b>ME-600C</b>	3.50	89	5.75	146	2.00	51	6.00	152	4.00	102

### Slab-to-Slab

Model #	Installation Width				Joint Opening "A"					
	Min		Max		Min		Max		Total	
	in	mm	in	mm	in	mm	in	mm	in	mm
<b>MM-150</b>	N/A	N/A	N/A	N/A	0.50	13	2.50	64	2.00	51
<b>MM-200</b>	1.00	25	2.00	51	0.75	19	4.00	102	3.25	83
<b>MM-800</b>	2.00	51	4.00	102	1.75	44	8.00	203	6.25	159

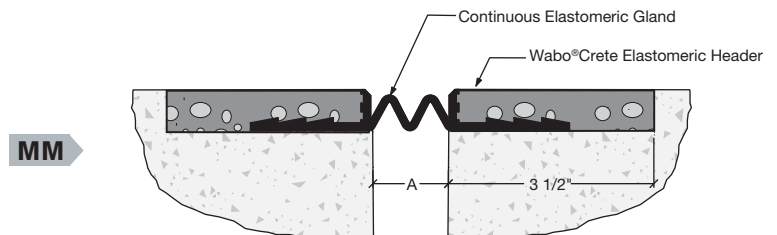
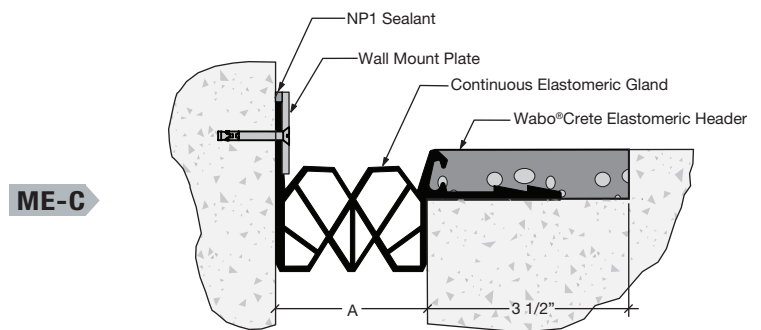
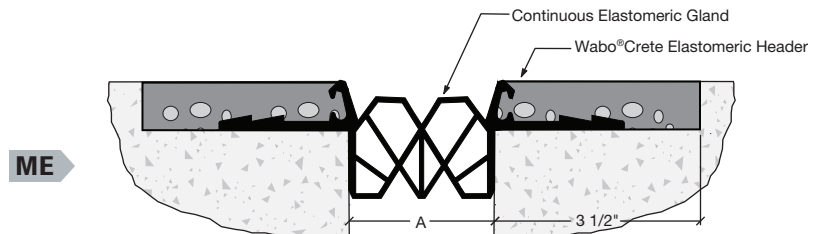

# Wabo®Crete Membrane

(continued)

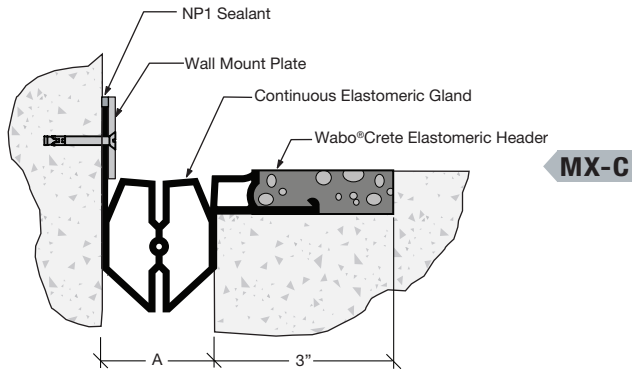
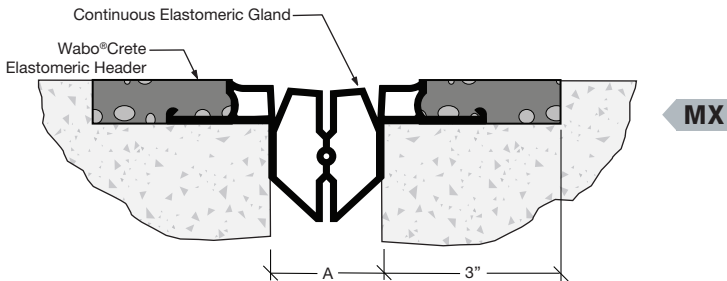
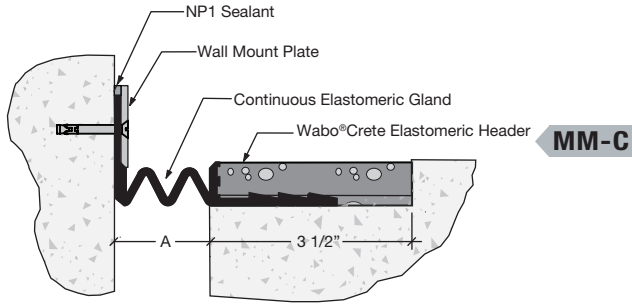

## Slab-to-Wall

Model #	Installation Width				Joint Opening "A"					
	Min		Max		Min		Max		Total	
	in	mm	in	mm	in	mm	in	mm	in	mm
<b>MM-150C</b>	N/A	N/A	N/A	N/A	0.50	13	2.50	64	2.00	51
<b>MM-200C</b>	1.00	25	2.00	51	0.75	19	4.00	102	3.25	83
<b>MM-800C</b>	2.00	51	4.00	102	1.75	44	8.00	203	6.25	159

## Slab-to-Slab

Model #	Installation Width				Joint Opening "A"					
	Min		Max		Min		Max		Total	
	in	mm	in	mm	in	mm	in	mm	in	mm
<b>MX-200</b>	0.75	19	2.00	51	0.63	16	4.00	102	3.38	86

## Slab-to-Wall

Model #	Installation Width				Joint Opening "A"					
	Min		Max		Min		Max		Total	
	in	mm	in	mm	in	mm	in	mm	in	mm
<b>MX-200C</b>	0.75	19	2.00	51	0.63	16	4.00	102	3.38	86

# Jeene®

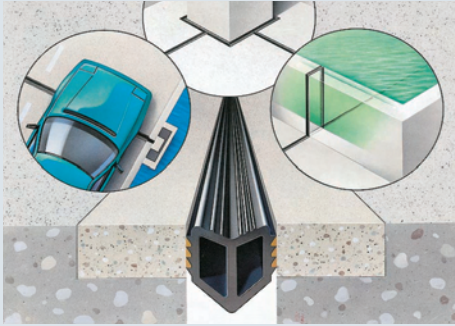

## FEATURES

- Patented air inflated installation
- Rapid Installation
- Resistant to ozone, chemicals, oil and fuel
- Watertight
- Accommodates complex transitions
- Hydrostatic applications

### Slab-to-Slab

Model #	Required Joint Gap*				Horizontal Movement Range "A"					
	Width		Depth "D"		Min		Max		Total	
	in	mm	in	mm	in	mm	in	mm	in	mm
25 FW	1.000	25	2.000	51	0.690	17	1.313	34	0.625	16
40 FW	1.625	41	3.000	76	1.000	25	2.000	51	1.000	25
50 FW	2.000	51	3.500	89	1.375	35	2.625	66	1.250	32
65 FW	2.500	64	4.375	111	1.625	41	3.375	86	1.750	44
75 FW	3.000	76	4.750	121	2.000	51	4.000	102	2.000	51
100 FW	3.875	98	5.875	149	2.690	68	5.313	135	2.625	67
125 FW	5.000	127	7.000	178	3.375	86	6.625	168	3.250	83

\*Note: Width measurements represent the maximum concrete gap width at time of installation. Depth measurements represent the minimum recommended concrete depth. All measurements have been converted from metric and rounded to nearest 1/8".

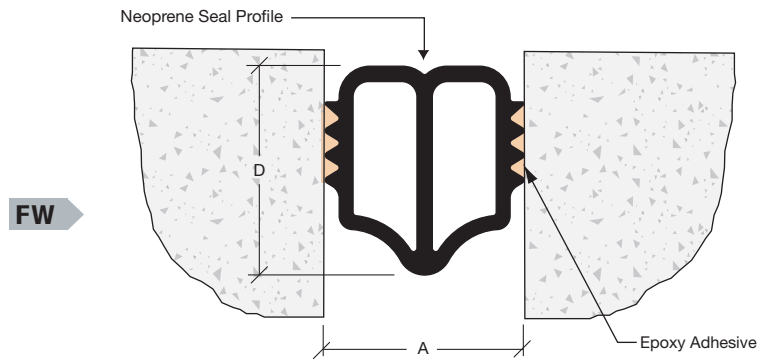

FW

### Slab-to-Slab

Model #	Required Joint Gap*				Horizontal Movement Range "A"					
	Width		Depth "D"		Min		Max		Total	
	in	mm	in	mm	in	mm	in	mm	in	mm
25 W	1.000	25	2.000	51	0.500	13	1.500	38	1.000	25
40 W	1.625	41	2.750	70	0.750	19	2.250	57	1.500	38
50 W	2.000	51	3.125	79	1.000	25	3.000	76	2.000	51
65 W	2.500	64	4.125	105	1.250	32	3.750	95	2.500	65
75 W	3.000	76	5.375	137	1.500	38	4.500	114	3.000	76
100 W	3.875	98	5.500	140	2.000	51	6.000	152	4.000	102

\*Note: Width measurements represent the maximum concrete gap width at time of installation. Depth measurements represent the minimum recommended concrete depth. All measurements have been converted from metric and rounded to nearest 1/8".

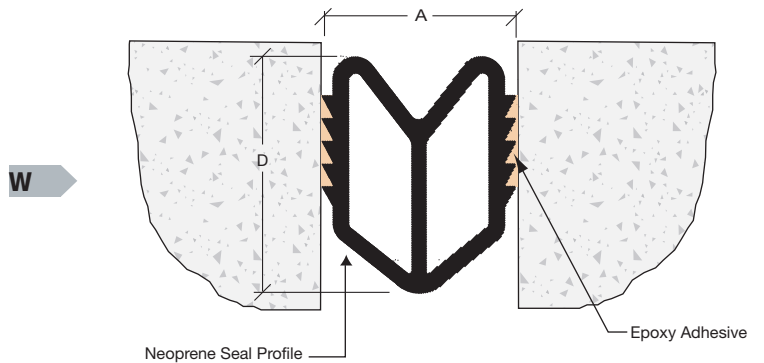

W



## FEATURES

- Quick installation
- Cost effective
- Resistant to ozone, chemicals, oil & fuel
- Closed cell neoprene foam
- Epoxy bonded
- Conforms to irregular openings

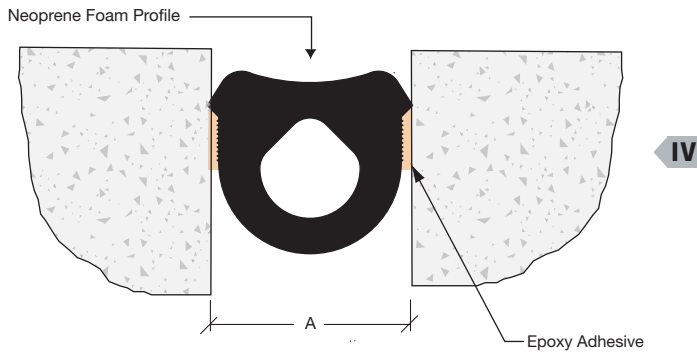

IV

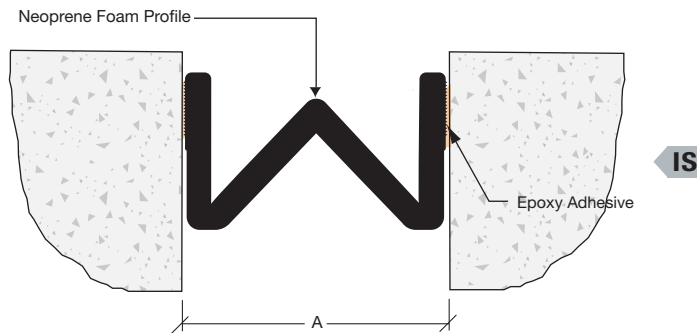

IS

# Wabo® InverSeal



## Slab-to-Slab

Model #	Nominal Seal Width		Min Install Width		Joint Opening "A"					
					Min		Max		Total	
	in	mm	in	mm	in	mm	in	mm	in	mm
IV-100	1.00	25	0.80	20	0.45	11	1.25	32	0.8	20
IV-150	1.50	38	1.20	30	0.68	17	1.88	48	1.2	31
IV-200	2.00	51	1.60	41	0.90	23	2.50	64	1.6	41
IV-250	2.50	64	2.00	51	1.13	29	3.13	79	2.0	51
IV-300	3.00	76	2.40	61	1.35	34	3.75	95	2.4	61
IV-400	4.00	102	3.20	81	1.80	46	5.00	127	3.2	81

## Slab-to-Slab

Model #	Nominal Seal Width		Min Install Width		Joint Opening "A"					
					Min		Max		Total	
	in	mm	in	mm	in	mm	in	mm	in	mm
IS-900	5.00	127	2.00	51	0.50	13	9.00	229	8.5	216



# Wabo® SeismicSpan



## FEATURES

- Seismic self-centering bar technology
- Stainless steel or aluminum covers
- Surface or flush mounted models
- Snap-in moisture barrier

### SURFACE MOUNT Slab-to-Slab

Model #	Joint Opening "A"						System Width "B"	
	Min		Max		Total		in	mm
	in	mm	in	mm	in	mm		
APS-200	1.375	35	3.0	76	1.625	41	5.75	146
APS-400	1.375	35	6.0	152	4.625	117	8.75	222
APS-600	1.375	35	9.0	229	7.625	194	11.75	298
APS-800	1.375	35	12.0	305	10.625	270	14.75	375
APS-1000	1.375	35	15.0	381	13.625	346	17.75	451
APS-1200	1.375	35	18.0	457	16.625	422	20.75	527
APS-1500	1.375	35	23.0	584	21.625	549	25.75	654
APS-1800	1.375	35	27.0	686	25.625	657	29.75	756

### Slab-to-Wall

APS-200C	1.375	35	2.625	67	1.250	32	3.750	95
APS-400C	1.375	35	5.125	130	3.750	95	6.250	159
APS-600C	1.375	35	7.625	294	6.250	159	8.750	222
APS-800C	1.375	35	10.125	257	8.750	222	11.250	286
APS-1000C	6.000	152	12.625	321	6.625	169	13.750	349
APS-1200C	7.000	178	15.125	384	8.125	206	16.250	413
APS-1500C	8.500	216	19.125	486	10.625	270	20.250	514
APS-1800C	10.000	254	22.625	575	12.625	321	23.750	603

### FLUSH MOUNT Slab-to-Slab

APX-200	1.375	35	3.0	76	1.625	41	6.25	159
APX-400	1.375	35	6.0	152	4.625	117	10.25	260
APX-600	1.375	35	9.0	229	7.625	194	14.25	362
APX-800	1.375	35	12.0	305	10.625	270	18.25	464
APX-1000	1.375	35	15.0	381	13.625	346	22.25	565
APX-1200	1.375	35	18.0	457	16.625	422	26.25	667
APX-1500	1.375	35	23.0	584	21.625	549	32.75	832
APX-1800	1.375	35	27.0	686	25.625	657	38.25	972

### Slab-to-Wall

APX-200C	1.375	35	2.625	67	1.250	32	4.125	104
APX-400C	1.375	35	5.125	130	3.750	95	7.125	181
APX-600C	1.375	35	7.625	194	6.250	159	10.125	257
APX-800C	1.375	35	10.125	257	8.750	222	13.125	333
APX-1000C	6.000	152	12.625	321	6.625	169	16.125	410
APX-1200C	7.000	178	15.125	384	8.125	206	19.125	486
APX-1500C	8.500	216	19.125	486	10.625	270	23.875	606
APX-1800C	10.000	254	22.625	575	12.625	321	28.125	714

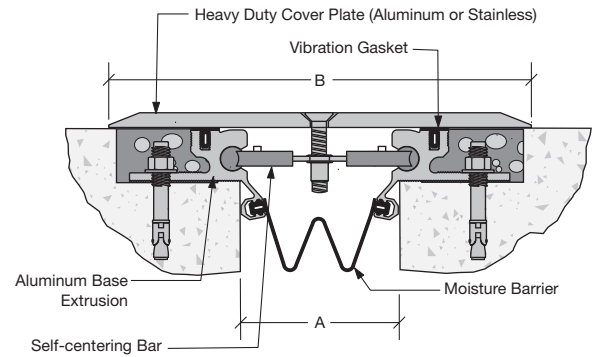

APS

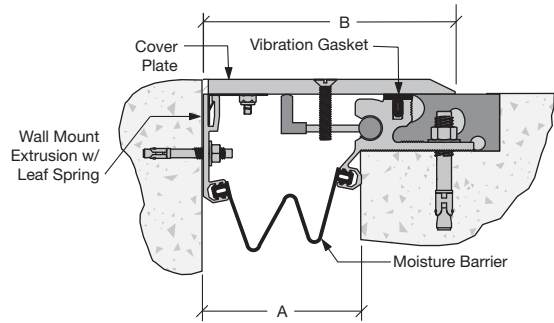

APS-C

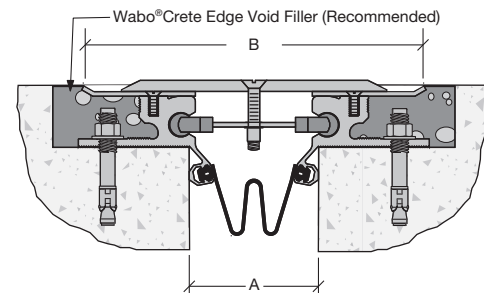

APX

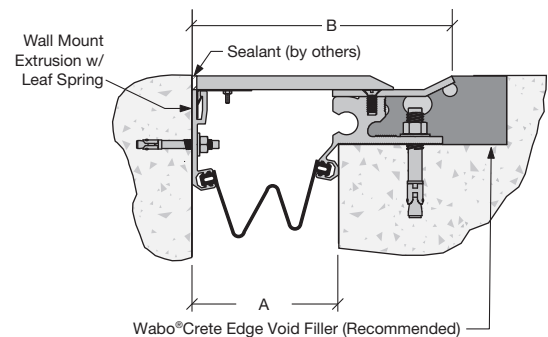

APX-C





FEATURES

- Reduces tripping hazards
- Hinged rubber cover plate
- Quiet, smooth riding surface
- Handles vehicular traffic
- Ideal for pedestrian walkways
- Compensates for vertical offset

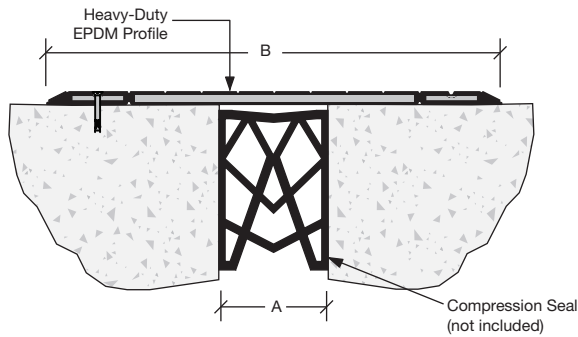

SFP

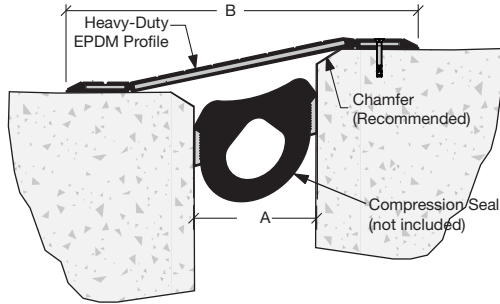

SFP

Vertical Offset

# Wabo® SafetyFlex

(U.S. Patent #: 6,751,918)



**Slab-to-Slab**

Model #	Joint Opening "A"						System Width "B"	
	Min		Max		Total		in	mm
	in	mm	in	mm	in	mm		
SFP-600	0.00	0	6.00	152	6.00	152	12.00	305
SFP-1000	0.00	0	10.00	254	10.00	254	18.00	457
SFP-1200	0.00	0	12.00	305	12.00	305	17.50	445
SFP-1800	0.00	0	18.00	457	18.00	457	23.50	597

*Note: Minimum and maximum joints openings based on use of WaboSafetyFlex only. Underlying expansion joint system may have limited movement range.*



# Wabo®Crete StripSeal

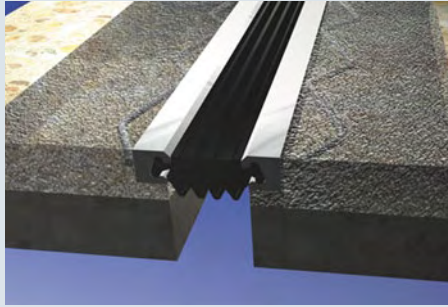

## FEATURES

- Original elastomeric header
- Withstands freeze-thaw cycles
- Superior bonding
- Watertight
- Traffic ready within hours

### Slab-to-Slab

Model #	Min Install Width		Joint Opening "A"					
			Min		Max		Total	
	in	mm	in	mm	in	mm	in	mm
SE-300	1.50	38	0.00	0	3.00	76	3.00	76
SE-400	1.50	38	0.00	0	4.00	102	4.00	102
SE-500	2.00	51	0.00	0	5.00	127	5.00	127
SE-800	3.00	76	0.50	13	8.50	216	8.00	203

### Slab-to-Slab

Model #	Min Install Width		Joint Opening "A"					
			Min		Max		Total	
	in	mm	in	mm	in	mm	in	mm
SEC-225	2.00	51	1.50	38	4.00	102	2.50	64
SEC-400	2.50	64	2.00	51	6.00	152	4.00	102

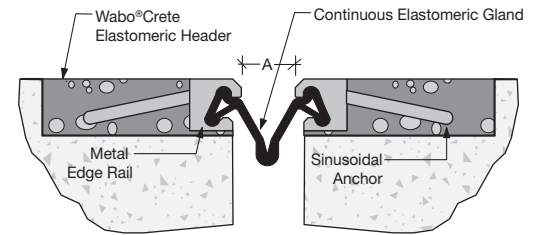

### SE Gland

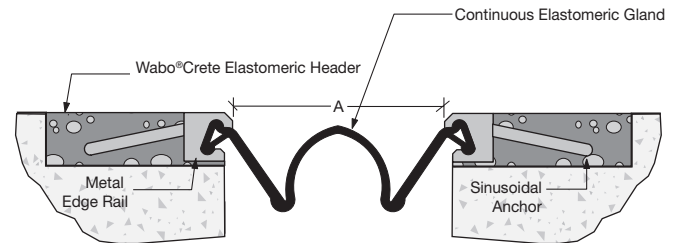

### SEC Gland

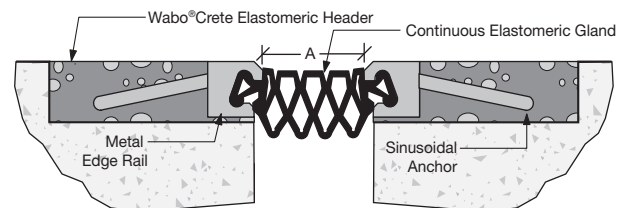



FEATURES

- Heavy-duty construction
- Non-skid surface
- Mechanically fastened
- Steel reinforced EPDM blocks
- Tongue and groove interlock

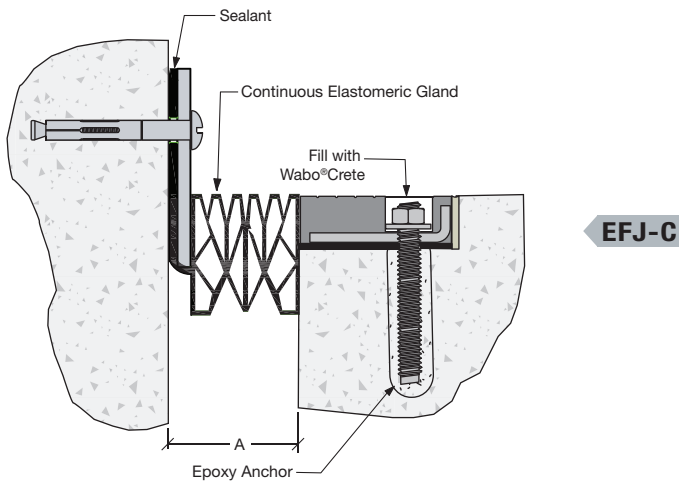
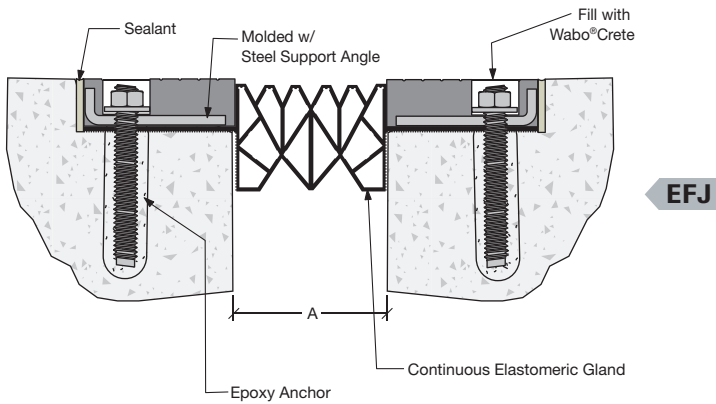

# Wabo®ElastoFlex



## Slab-to-Slab

Model #	Joint Opening "A"					
	Min		Max		Total	
	in	mm	in	mm	in	mm
EFJ-225	1.00	25	2.25	57	1.25	32
EFJ-400	1.50	38	4.00	102	2.50	64
EFJ-600	2.00	51	6.00	152	4.00	102

## Slab-to-Wall

Model #	Joint Opening "A"					
	Min		Max		Total	
	in	mm	in	mm	in	mm
EFJ-225C	1.00	25	2.25	57	1.25	32
EFJ-400C	1.50	38	4.00	102	2.50	64
EFJ-600C	2.00	51	6.00	152	4.00	102

# Wabo® CompressionSeal



## FEATURES

- Water resistant seal
- 30 year proven history
- Colorable seals (WE only)
- Heavy-duty neoprene seals (WA only)
- Floor and wall applications
- Economical and simple

### Slab-to-Slab

Model #	Joint Opening "A"						Installation Width		Groove Depth "B"	
	Min		Max		Total		in		mm	
	in	mm	in	mm	in	mm	in	mm	in	mm
WE-100*	0.50	13	1.50	38	1.00	25	1.00	25	N/A	N/A
WE-225	0.69	17	1.94	49	1.25	32	1.38	35	1.88	48
WE-250	1.06	27	2.13	54	1.06	27	1.63	41	2.38	60
WE-300	1.44	37	2.56	65	1.13	29	2.00	51	2.53	64
WE-400	1.25	32	3.38	86	2.13	54	2.38	60	3.19	81
WE-500	1.44	37	4.25	108	2.19	71	2.88	73	3.63	92
WE-600	1.81	46	5.13	130	3.31	84	3.50	89	4.63	117

\*Note: WE-100 not recommended for horizontal applications

### Slab-to-Slab

Model #	Total Movement		Groove Width "A"				Min Install Width		Groove Depth "B"		Width		Height	
			Min		Max		in		mm		in		mm	
	in	mm	in	mm	in	mm	in	mm	in	mm	in	mm	in	mm
WA-162	0.76	19	0.63	16	1.38	35	1.00	25	2.13	54	1.63	41	1.63	41
WA-175	0.81	21	0.69	17	1.50	38	1.00	25	2.63	67	1.75	44	2.00	51
WA-200	0.81	21	0.88	22	1.69	43	1.25	32	2.63	67	2.00	51	2.00	51
WA-225	0.96	24	0.95	24	1.91	49	1.38	35	3.00	76	2.25	57	2.25	57
WA-250	1.13	29	1.00	25	2.13	54	1.50	38	3.56	90	2.50	64	2.50	64
WA-300	1.44	37	1.13	29	2.55	65	1.75	44	4.31	110	3.00	76	3.00	76
WA-350	1.63	41	1.38	35	3.00	76	2.25	57	4.44	113	3.50	89	3.50	89
WA-400	1.75	44	1.63	41	3.38	86	2.50	64	5.00	127	4.00	102	4.00	102
WA-500	2.56	65	1.69	43	4.25	108	3.00	76	5.94	151	5.00	127	5.00	127
WA-600	3.10	79	2.00	51	5.13	130	3.50	89	7.75	197	6.00	152	6.00	152

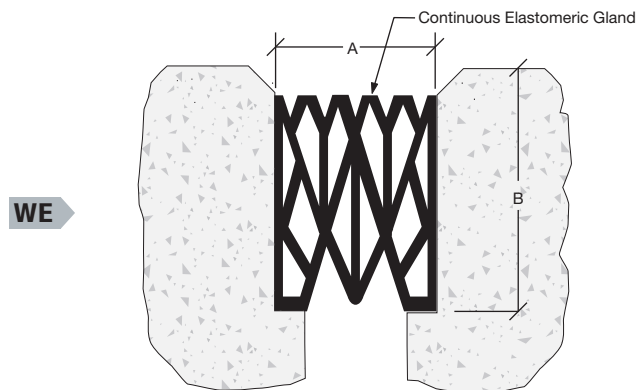

WE

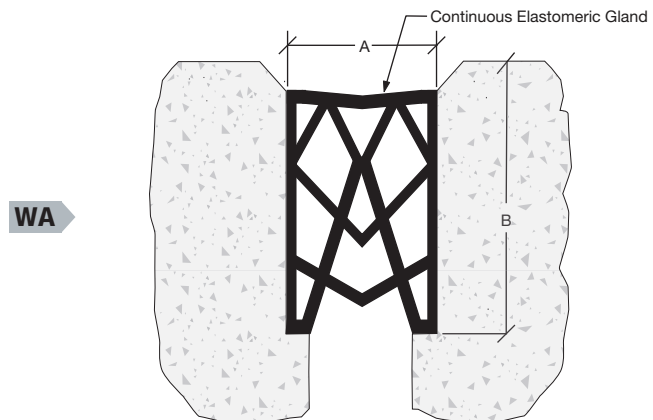

WA



FEATURES

- Forms to treads and risers
- Patented design
- Watertight continuous seal
- Non-slip ribbed surface
- For pedestrian traffic only

# Wabo® StadiaFlex

(U.S. Patent #: 5,887,400)

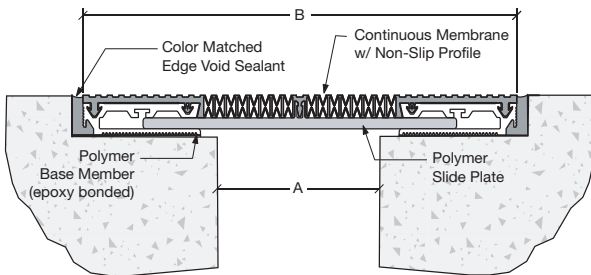

SDF

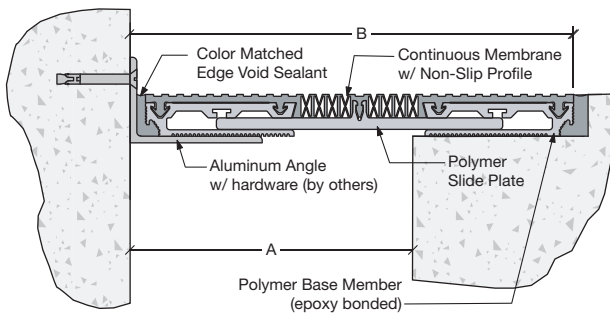

SDF-C

### Slab-to-Slab

Model #	Joint Opening "A"						Width "B"	
	Min		Max		Total		in	mm
	in	mm	in	mm	in	mm		
SDF-200	0.75	19	3.38	86	2.63	51	8.63	219
SDF-300	1.00	25	5.00	127	4.00	102	9.50	241
SDF-400	2.00	51	6.00	152	4.00	102	9.50	241

### Slab-to-Wall

Model #	Joint Opening "A"						Width "B"	
	Min		Max		Total		in	mm
	in	mm	in	mm	in	mm		
SDF-200C	4.56	116	7.19	183	2.63	51	8.63	219
SDF-300C	4.75	121	8.75	222	4.00	102	9.50	241
SDF-400C	4.75	121	8.75	222	4.00	102	9.50	241



# Wabo® WeatherSeal II



## Wall-to-Wall

Model #	Joint Opening "A"						System Depth "B"	
	Min		Max		Total		in	mm
	in	mm	in	mm	in	mm		
WS-100	0.75	19	1.25	32	0.50	13	1.50	38
WS-150	1.13	29	1.88	48	0.75	19	2.00	51
WS-200	1.50	37	2.50	64	1.00	27	2.00	51
WS-250	1.88	44	3.13	79	1.25	35	2.00	51
WS-300	2.25	54	3.75	95	1.63	41	2.50	64
WS-350	2.63	64	4.38	111	1.75	47	2.50	64
WS-400	3.00	73	5.00	127	2.00	54	2.50	64
WS-500	3.75	92	6.25	159	2.50	67	4.00	102

Note: Other sizes are available. Contact WBA for details.



## FEATURES

- Versatile movement +/-25%
- Ease of installation
- Colorable

WS

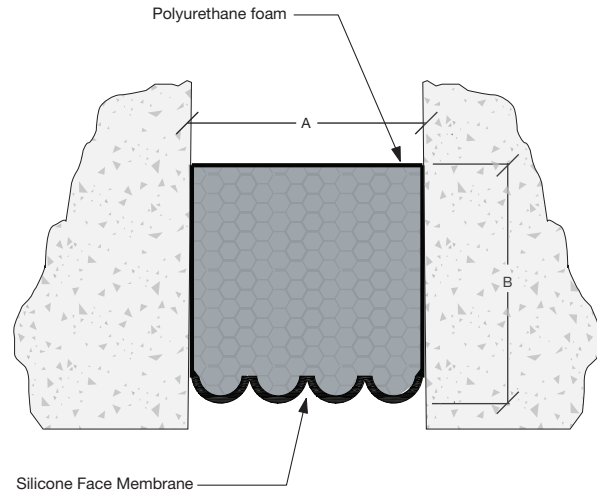

# Wabo® Seismic WeatherSeal



## Wall-to-Wall

Model #	Joint Opening "A"						System Depth "B"	
	Min		Max		Total		in	mm
	in	mm	in	mm	in	mm		
SWS-100	0.50	13	1.50	38	1.00	25	1.50	38
SWS-150	0.75	19	2.25	57	1.50	38	2.00	51
SWS-200	1.00	25	3.00	76	2.00	51	2.00	51
SWS-250	1.25	32	3.75	95	2.50	64	2.00	51
SWS-300	1.50	38	4.50	114	3.00	76	3.00	76
SWS-350	1.75	44	5.25	133	3.50	89	3.00	76
SWS-400	2.00	51	6.00	152	4.00	102	4.00	102
SWS-500	2.50	64	7.50	191	5.00	127	4.00	102
SWS-600	3.00	76	9.00	229	6.00	152	4.00	102

Note: Other sizes are available. Contact WBA for details.



## FEATURES

- Versatile movement +/-50%
- Ease of installation
- Colorable
- Pre-compressed

SWS

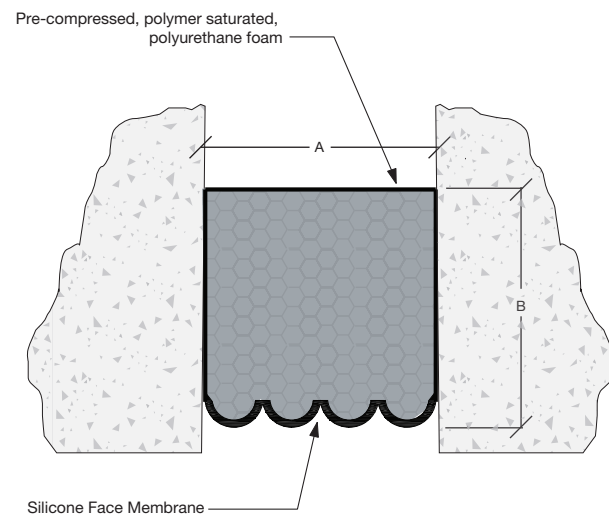



## FEATURES

- Flexible gutter system
- Cost effective
- Fabric reinforced neoprene
- Optional drain tube assembly
- Primary waterproofing
- Secondary waterproofing

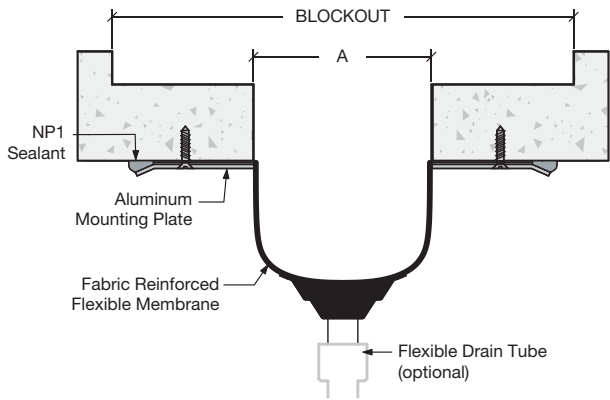

**USG**

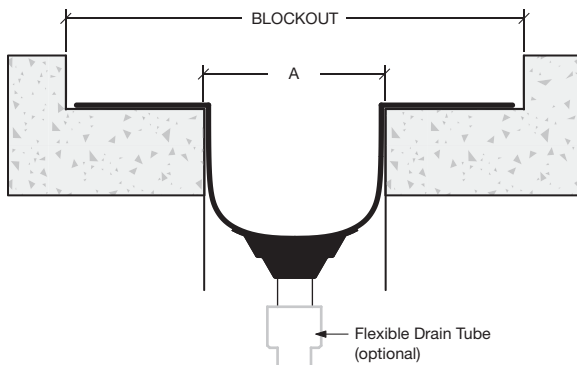

**BOG**

# Wabo® GutterFlex

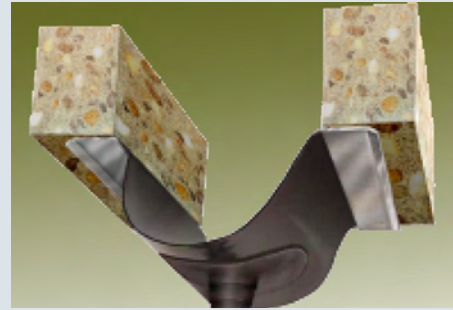

## Under-slab

Model #	Joint Opening "A"						Membrane Width	
	Min		Max		Total		in	mm
	in	mm	in	mm	in	mm		
<b>USG-12N</b>	0.00	0	5.00	127	5.00	127	12.00	305
<b>USG-18N</b>	0.00	0	11.00	279	11.00	279	18.00	457
<b>USG-24N</b>	0.00	0	17.00	432	17.00	432	24.00	610
<b>USG-30N</b>	0.00	0	23.00	584	23.00	584	30.00	762
<b>USG-36N</b>	0.00	0	28.00	711	28.00	711	36.00	914
<b>USG-42N</b>	0.00	0	34.00	864	34.00	864	42.00	1067
<b>USG-48N</b>	0.00	0	41.00	1041	41.00	1041	48.00	1219

## Block-out

Model #	Joint Opening "A"						Membrane Width	
	Min		Max		Total		in	mm
	in	mm	in	mm	in	mm		
<b>BOG-12N</b>	1.00	25	4.00	102	3.00	76	12.00	305
<b>BOG-18N</b>	1.00	25	10.00	254	9.00	229	18.00	457
<b>BOG-24N</b>	1.00	25	16.00	406	15.00	381	24.00	610
<b>BOG-30N</b>	1.00	25	22.00	559	21.00	533	30.00	762
<b>BOG-36N</b>	1.00	25	27.00	686	26.00	660	36.00	914
<b>BOG-42N</b>	1.00	25	33.00	838	32.00	813	42.00	1067
<b>BOG-48N</b>	1.00	25	40.00	1016	39.00	991	48.00	1219

# Wabo®UreFlex

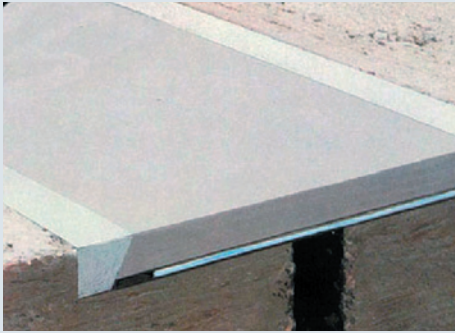

## Slab-to-Slab

Model #	Joint Opening "A"						System Width "B"	
	Min		Max		Total		in	mm
	in	mm	in	mm	in	mm		
T-3	0.00	0	0.50	13	0.50	13	4.00	102
T-4	0.25	6	1.00	25	0.75	19	5.00	127
T-6	0.50	13	1.50	38	1.00	25	7.00	178
T-8	0.75	19	2.25	57	1.50	38	9.00	229
T-10	1.00	25	3.00	76	2.00	51	11.00	279
T-12	0.50	13	3.00	76	2.50	64	13.00	330

## Slab-to-Wall

Model #	Joint Opening "A"						System Width "B"	
	Min		Max		Total		in	mm
	in	mm	in	mm	in	mm		
T-3C	0.00	0	0.50	13	0.50	13	4.00	102
T-4C	0.25	6	1.00	25	0.75	19	5.00	127
T-6C	0.50	13	1.50	38	1.00	25	7.00	178
T-8C	0.75	19	2.25	57	1.50	38	9.00	229
T-10C	1.00	25	3.00	76	2.00	51	11.00	279
T-12C	0.50	13	3.00	76	2.50	64	13.00	330

# Wabo®SiliconeSeal



## FEATURES

- Premold T-joint
- Continuous, watertight seal
- Polymeric nosing
- Easy installation

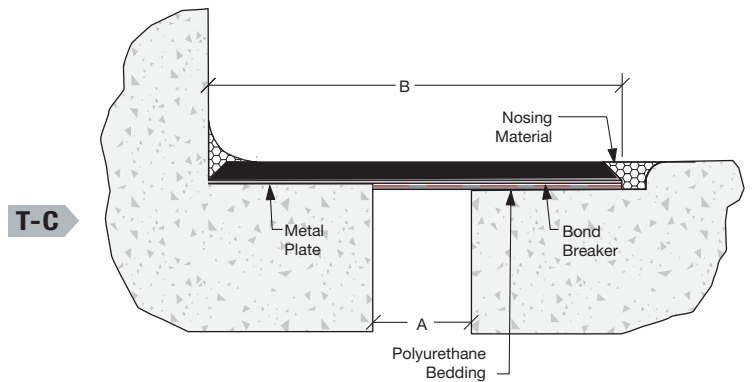
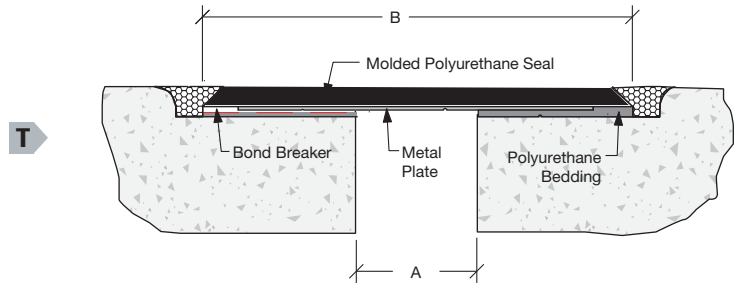

## FEATURES

- +100%/-50% joint movement
- Rapid Cure-skins within 20 minutes and can generally accept traffic after 1 hour
- Self-leveling and quick curing
- No primer required

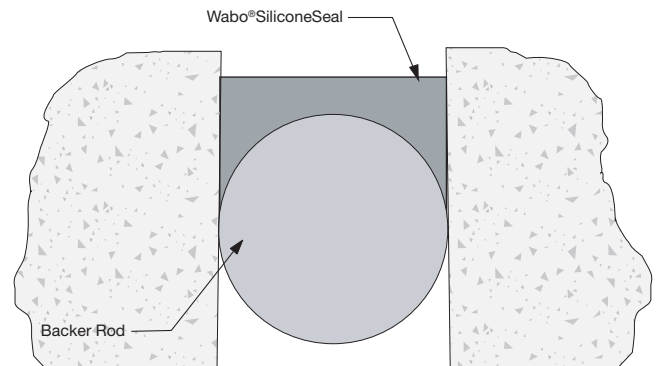





## FEATURES

- For plaza decks & split slab conditions
- Integrates with deck waterproofing
- Heavy duty aluminum side rails
- System heights from 1.5" to 4.5"
- Accommodates pavers and concrete toppings

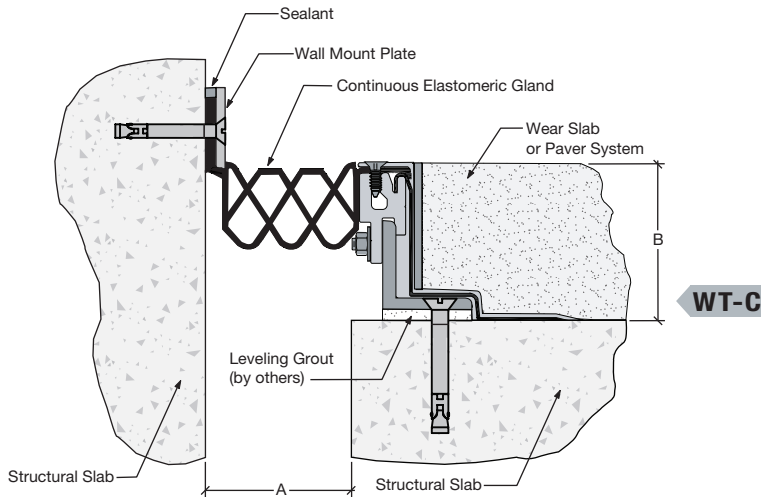
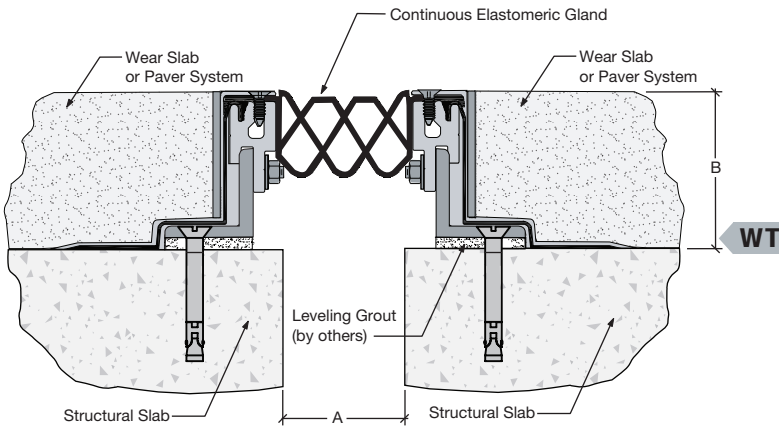

# Wabo® WaterTite



## Slab-to-Slab

Model #	Joint Opening "A"						System Height "B"	
	Min		Max		Total		in	mm
	in	mm	in	mm	in	mm		
WT-200/150	0.75	19	3.00	76	2.25	57	1.50	38
WT-200/250	0.75	19	3.00	76	2.25	57	2.50	64
WT-200/350	0.75	19	3.00	76	2.25	57	3.50	89
WT-200/450	0.75	19	3.00	76	2.25	57	4.50	114
WT-400/150	1.50	38	5.00	127	3.50	89	1.50	38
WT-400/250	1.50	38	5.00	127	3.50	89	2.50	64
WT-400/350	1.50	38	5.00	127	3.50	89	3.50	89
WT-400/450	1.50	38	5.00	127	3.50	89	4.50	114
WT-800/150	2.50	64	12.00	305	9.50	241	1.50	38
WT-800/250	2.50	64	12.00	305	9.50	241	2.50	64
WT-800/350	2.50	64	12.00	305	9.50	241	3.50	89
WT-800/450	2.50	64	12.00	305	9.50	241	4.50	114

Note: Other system heights are available. Contact WBA for details.

## Slab-to-Wall

Model #	Joint Opening "A"						System Height "B"	
	Min		Max		Total		in	mm
	in	mm	in	mm	in	mm		
WT-200/150C	0.75	19	3.00	76	2.25	57	1.50	38
WT-200/250C	0.75	19	3.00	76	2.25	57	2.50	64
WT-200/350C	0.75	19	3.00	76	2.25	57	3.50	89
WT-200/450C	0.75	19	3.00	76	2.25	57	4.50	114
WT-400/150C	1.50	38	5.00	127	3.50	89	1.50	38
WT-400/250C	1.50	38	5.00	127	3.50	89	2.50	64
WT-400/350C	1.50	38	5.00	127	3.50	89	3.50	89
WT-400/450C	1.50	38	5.00	127	3.50	89	4.50	114
WT-800/150C	2.50	64	12.00	305	9.50	241	1.50	38
WT-800/250C	2.50	64	12.00	305	9.50	241	2.50	64
WT-800/350C	2.50	64	12.00	305	9.50	241	3.50	89
WT-800/450C	2.50	64	12.00	305	9.50	241	4.50	114

Note: Other system heights are available. Contact WBA for details.



# Wabo® WeatherSeam



## Wall-to-Wall

Model #	No. Of Seals	Joint Opening "A"		Total Movement	
		in	mm	in	mm
WSW-200	1	2.00	51	2.63	67
WSW-300	1	3.00	76	5.13	130
WSW-400	1	4.00	102	4.75	121
WSW-500	1	5.00	127	6.75	171
WSW-600	1	6.00	152	9.50	241
WSW-800	2	8.00	203	9.63	244
WSW-1000	2	10.00	254	13.63	346
WSW-1200	2	12.00	305	19.13	486
WSW-900	3	9.00	229	15.38	391
WSW-1500	3	15.00	381	20.25	514
WSW-1600	4	16.00	406	19.00	483
WSW-1800	3	18.00	457	28.50	724
WSW-2000	4	20.00	508	27.00	686
WSW-2400	4	24.00	610	38.00	965

Note: Specify with or without moisture barrier

## Wall-to-Wall

Model #	No. Of Seals	Joint Opening "A"		Total Movement	
		in	mm	in	mm
WSE-200	1	2.00	51	2.63	67
WSE-300	1	3.00	76	5.13	130
WSE-400	1	4.00	102	4.75	121
WSE-500	1	5.00	127	6.75	171
WSE-600	1	6.00	152	9.50	241

Note: Specify with or without moisture barrier



## FEATURES

- Weathertight sealing design
- Multi-directional / seismic movement
- Moisture barrier
- Colorable seals
- Mechanical or epoxy anchors

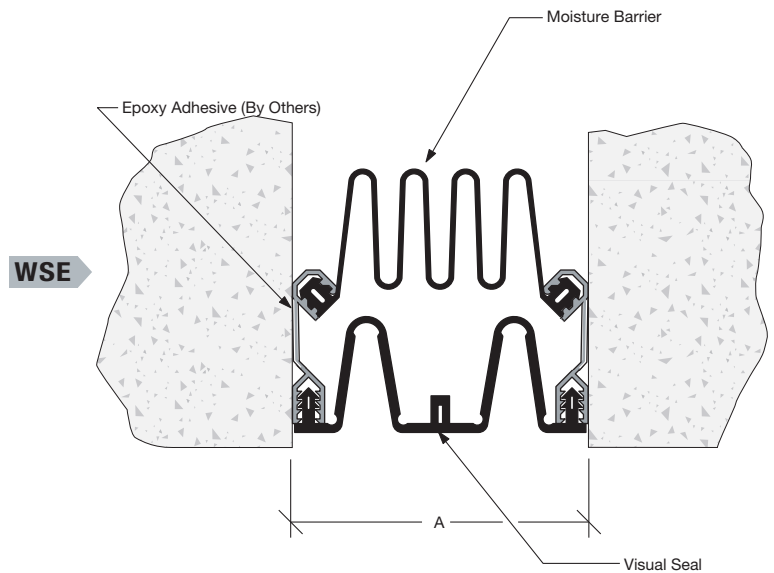
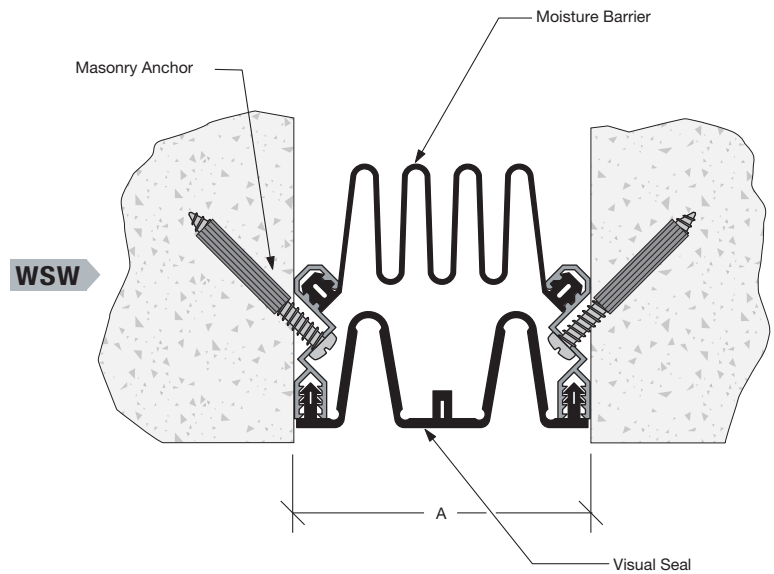



FEATURES

- Versatile movement
- No mechanical anchors
- UV stable polymer impregnated foam
- Pre-Compressed

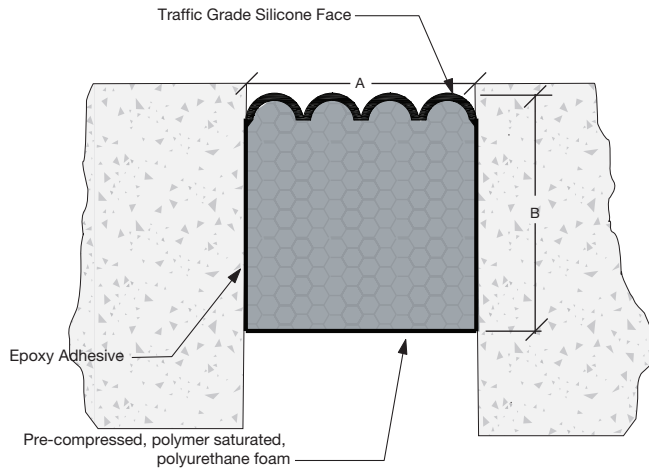

EH

# Wabo®HSeal

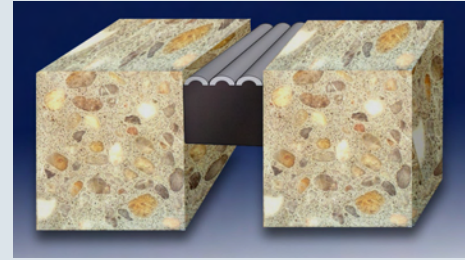

## Slab-to-Slab

Model #	System Depth "B"		Joint Opening "A"					
			Min		Max		Total	
	in	mm	in	mm	in	mm	in	mm
25EH	1.50	38	0.50	13	1.50	38	1.00	25
40EH	2.00	51	0.75	19	2.25	57	1.50	38
50EH	2.00	51	1.00	25	3.00	76	2.00	51
65EH	2.00	51	1.25	32	3.75	95	2.50	64
75EH	3.00	76	1.50	38	4.50	114	3.00	76
90EH	3.00	76	1.75	44	5.25	133	3.50	89
100EH	4.00	102	2.00	51	6.00	152	4.00	102



FEATURES

- Can withstand hydrostatic pressure
- Resists Ultraviolet degradation and is chemically inert
- Working movement range of 60% compression and 30% tension
- Can accommodate varying joint widths

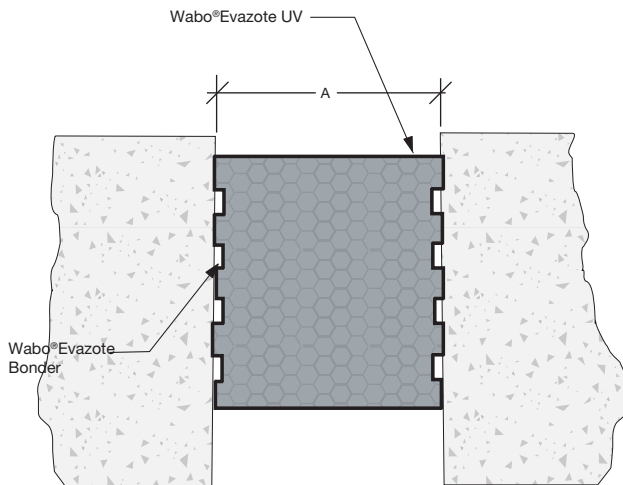

# Wabo®Evazote UV



## Slab-to-Slab

Model		Joint Opening "A"							
Width		Height		Min		Max		Total	
in	mm	in	mm	in	mm	in	mm	in	mm
1.00	25	1.00	25	0.40	10	1.30	33	0.90	23
1.25	32	2.00	51	0.50	13	1.63	41	1.13	29
1.56	40	2.00	51	0.63	16	2.03	51	1.40	36
1.72	44	2.00	51	0.75	19	2.25	57	1.50	38
1.88	48	2.00	51	0.75	19	2.43	62	1.68	43
2.19	56	2.00	51	0.88	22	2.85	72	1.97	50
2.50	64	2.00	51	1.00	25	3.25	83	2.25	57
2.81	71	2.50	64	1.12	28	3.65	93	2.53	64
3.13	79	2.50	64	1.25	32	4.07	103	2.82	72
3.44	87	2.50	64	1.38	35	4.47	114	3.09	78
3.75	95	2.50	64	1.50	38	4.88	124	3.38	86
4.06	103	3.00	76	1.62	41	5.28	134	3.66	93
4.38	111	3.00	76	1.75	44	5.69	145	3.94	100
4.69	119	3.00	76	1.87	47	6.08	154	4.21	107
5.00	127	4.00	102	2.00	51	6.50	165	4.50	114
5.38	137	4.00	102	2.15	55	6.98	177	4.83	123

Contact your WBA Representative with your special design requirements



# Wabo® Flame Guard I

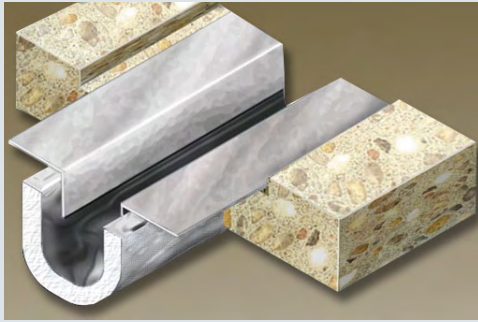

## Floor-to-Floor

Model #	Joint Opening		Total Movement	
	in	mm	in	mm
<b>3 Hour Rating Horizontal Applications</b>				
HFG-2.5-3	2.50	64	2.50	64
HFG-3-3	3.00	76	3.00	76
HFG-4-3	4.00	102	4.00	102
HFG-6-3	6.00	152	6.00	152
HFG-8-3	8.00	203	8.00	203
HFG-10-3	10.00	254	10.00	254
HFG-12-3	12.00	305	12.00	305
<b>4 Hour Rating Horizontal Applications</b>				
HFG-4-4	4.00	102	4.00	102
HFG-6-4	6.00	152	6.00	152
HFG-8-4	8.00	203	8.00	203
HFG-10-4	10.00	254	10.00	254
HFG-12-4	12.00	305	12.00	305



## FEATURES

- Fire ratings to 4 hrs. for nominal openings up to 12 inches
- Meets the requirements of  
ASTM E-1399, ASTM E-119,  
ICBO ES AC30, CAN/ULC-S101
- Cycle tested
- Listed with ITS
- No caulks or sealants required against adjacent construction

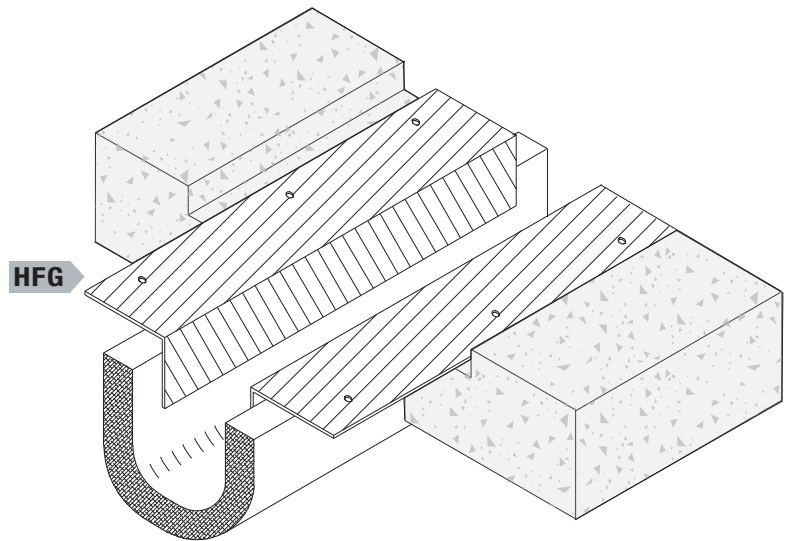



## FEATURES

- Fire ratings to 4 hrs. for 2 inch joint openings
- Fire ratings to 2 hrs. for joint openings up to 12 inches
- Meets the requirements of  
UL-2079, ASTM E-1966,  
ICBO ES AC30, CAN/ULC-S115
- Cycle tested
- Listed with UL and ULC

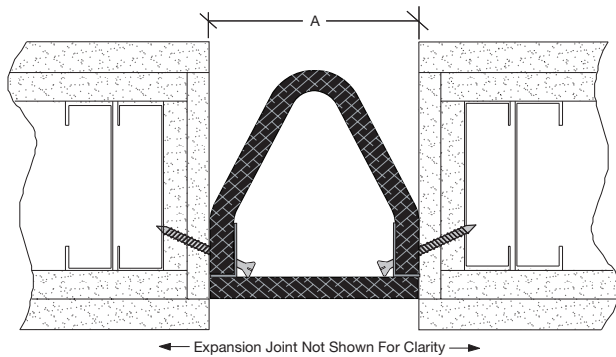

VFG

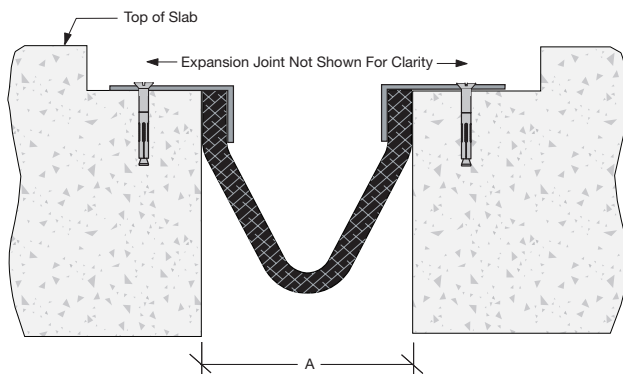

HFG

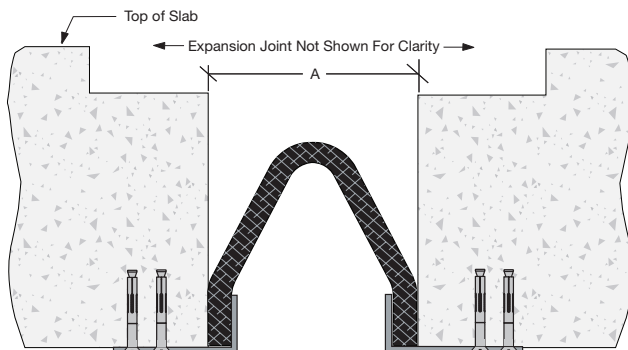

UFG

# Wabo® FlameGuard II

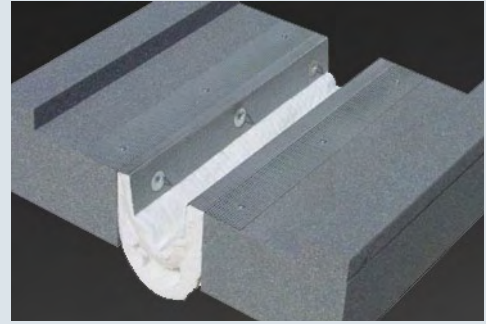

## Wall-to-Wall

Model #	Joint Opening "A"		Total Movement	
	in	mm	in	mm
<b>1 Hour Rating Vertical Applications</b>				
VFG-801	8.00	203	8.00	203
VFG-1001	10.00	254	10.00	254
VFG-1201	12.00	305	12.00	305
<b>2 Hour Rating Vertical Applications</b>				
VFG-202	2.00	51	2.00	51
VFG-402	4.00	102	4.00	102
VFG-602	6.00	152	6.00	152
VFG-802	8.00	203	8.00	203
VFG-1002	10.00	254	10.00	254
VFG-1202	12.00	305	12.00	305
VFG-1402	14.00	356	14.00	356
VFG-1602	16.00	406	16.00	406
VFG-1802	18.00	457	18.00	457
<b>3 Hour Rating Vertical Application</b>				
VFG-203	2.00	51	2.00	51

## Floor-to-Floor

<b>4 Hour Rating Horizontal Application</b>				
HFG-204	2.00	51	2.00	51
<b>1 Hour Rating Horizontal Applications</b>				
HFG-401, 401C	4.00	102	4.00	102
HFG-601, 601C	6.00	152	6.00	152
HFG-801, 801C	8.00	203	8.00	203
HFG-1001, 1001C	10.00	254	10.00	254
HFG-1201, 1201C	12.00	305	12.00	305
<b>2 Hour Rating Horizontal Applications</b>				
HFG-402, 402C	4.00	102	4.00	102
HFG-602, 602C	6.00	152	6.00	152
HFG-802, 802C	8.00	203	8.00	203
HFG-1002, 1002C	10.00	254	10.00	254
HFG-1202, 1202C	12.00	305	12.00	305

## Underslab

<b>2 Hour Rating Horizontal Applications</b>				
UFG-402, 402C	4.00	102	4.00	102
UFG-602, 602C	6.00	152	6.00	152
UFG-802, 802C	8.00	203	8.00	203
UFG-1002, 1002C	10.00	254	10.00	254
UFG-1202, 1202C	12.00	305	12.00	305



# Wabo® ThermoShield

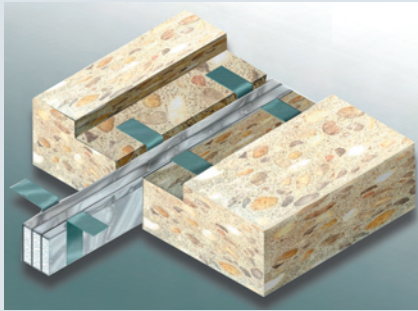

## FEATURES

- Fire ratings to 3 hrs. for nominal openings up to 4 inches
- Meets the requirements of
  - ASTM E-119
  - UL-263
  - CAN/ULC-S101
  - NFPA-251
- Listed with ITS
- No caulks or sealants required against adjacent construction
- No metal profiles utilized

### Wall-to-Wall

Model #	Joint Opening		Total Movement	
	in	mm	in	mm
<b>1 &amp; 2 Hour Rating Vertical Applications</b>				
VTS-1	1.00	25	1.00	25
VTS-1.5	1.50	38	1.50	38
VTS-2	2.00	51	2.00	51
VTS-2.5	2.50	64	2.50	64
VTS-3	3.00	76	3.00	76
VTS-3.5	3.50	89	3.50	89
VTS-4	4.00	102	4.00	102

### Floor-to-Floor

Model #	Joint Opening		Total Movement	
	in	mm	in	mm
<b>1, 2 &amp; 3 Hour Rating Horizontal Applications</b>				
HTS-1	1.00	25	1.00	25
HTS-1.5	1.50	38	1.50	38
HTS-2	2.00	51	2.00	51
HTS-2.5	2.50	64	2.50	64
HTS-3	3.00	76	3.00	76
HTS-3.5	3.50	89	3.50	89
HTS-4	4.00	102	4.00	102

VTS

HTS

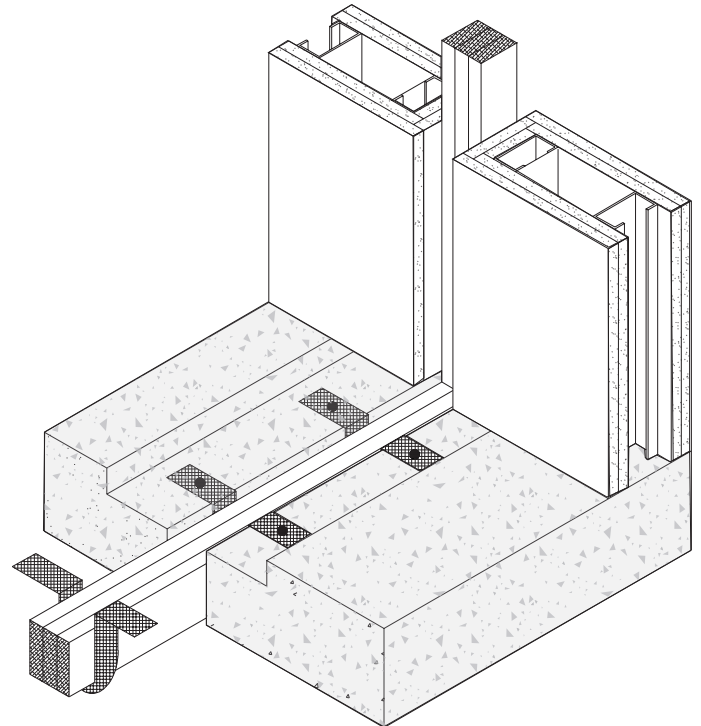

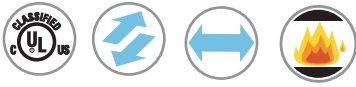

FEATURES

- Fire ratings to 2 hrs. for nominal openings up to 20 inches
- Meets UL-2079 and ICBO AC30
- Cycle tested for seismic lateral shear
- Listed with UL for Class II and III movement
- No caulks or sealants required against adjacent construction

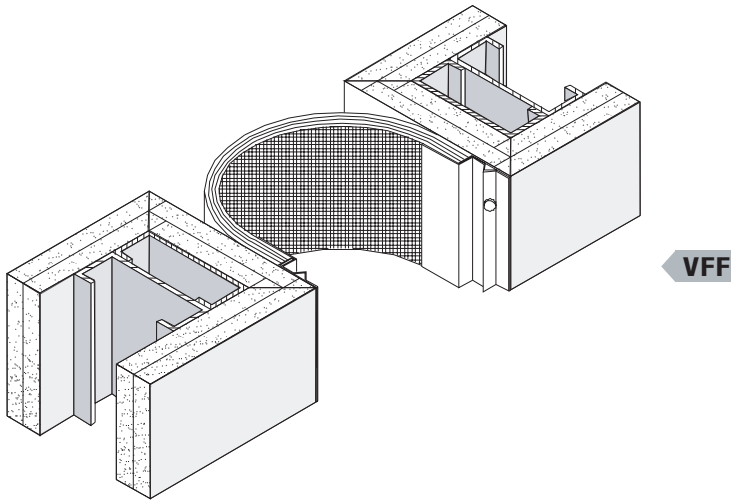

VFF

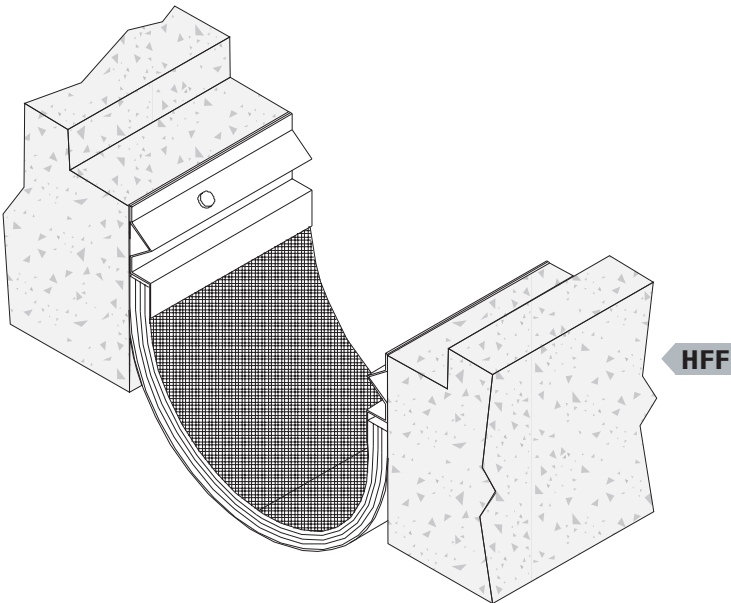

HFF

# Wabo® FireFlex

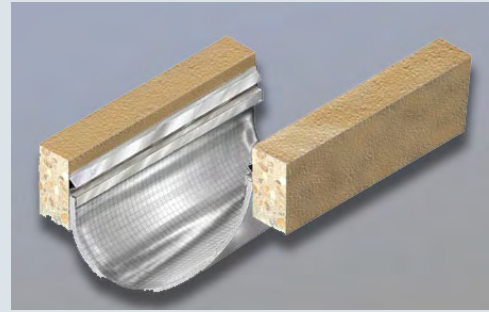

## Wall-to-Wall

Model #	Joint Opening		Total Movement	
	in	mm	in	mm
<b>2 Hour Horizontal Floor-to-Floor</b>				
VFF-01-2	1.00	25	1.00	25
VFF-02-2	2.00	51	2.00	51
VFF-03-2	3.00	76	3.00	76
VFF-04-2	4.00	102	4.00	102
VFF-05-2	5.00	127	5.00	127
VFF-06-2	6.00	152	6.00	152
VFF-08-2	8.00	203	8.00	203
VFF-10-2	10.00	254	10.00	254
VFF-12-2	12.00	305	12.00	305
VFF-14-2	14.00	356	14.00	356
VFF-16-2	16.00	406	16.00	406
VFF-18-2	18.00	457	18.00	457
VFF-20-2	20.00	508	20.00	508

## Floor-to-Floor

Model #	Joint Opening		Total Movement	
	in	mm	in	mm
<b>2 Hour Horizontal Floor-to-Floor</b>				
HFF-01-2	1.00	25	1.00	25
HFF-02-2	2.00	51	2.00	51
HFF-03-2	3.00	76	3.00	76
HFF-04-2	4.00	102	4.00	102
HFF-05-2	5.00	127	5.00	127
HFF-06-2	6.00	152	6.00	152
HFF-08-2	8.00	203	8.00	203
HFF-10-2	10.00	254	10.00	254
HFF-12-2	12.00	305	12.00	305
HFF-14-2	14.00	356	14.00	356
HFF-16-2	16.00	406	16.00	406
HFF-18-2	18.00	457	18.00	457
HFF-20-2	20.00	508	20.00	508



## The Expansion Control Company.

Founded in 1950, Watson Bowman Acme (WBA) is the world wide leader and recognized innovator in the development and manufacture of expansion control systems for the construction industry. WBA has taken great strides in achieving production efficiencies and environmental stewardship through its formal American Institute of Steel Construction, ISO 9001:2000 and RC 14001 certifications. These certifications enhance the company's commitment and passion for excellence. WBA uses its expertise in the design and manufacture of quality expansion control systems to produce products that perform and last. Watson Bowman Acme is "The Expansion Control Company".



**ARCHITECTURAL**



**BRIDGE & HIGHWAY**



**OPEN AIR STRUCTURES**

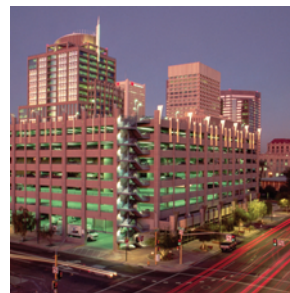

**PARKING STRUCTURES**

## Technical Expertise

Engineers and owners who are charged with the responsibility of searching out every possible avenue to extend the life of their structures turn to Watson Bowman Acme with their specific needs. More than 50 years of practical experience and knowledge in the Expansion Control industry allows WBA to develop solutions and make recommendations for the right product choice for your application.

## Innovation

Recognized as the industry leader in the development of expansion control systems, WBA has developed and manufactured products and solutions for some of the worlds' most unique and complex projects. Offering the broadest range of products and services in the construction industry, we are the only company servicing the Bridge and Highway, Architectural, Parking and Open Air Structures markets. We have a fully qualified team of professional engineers and designers backed by strong relationships with national testing labs and universities. Watson Bowman Acme has long been recognized for its innovation. We will continue to build on that reputation for years to come.

## Custom Solutions

WBA provides more than just technical expertise, we supply solutions that make good sense. We offer a growing range of high performance Wab® products and systems to provide long lasting solutions to difficult repair problems. We are fully resourced to deliver results and exceed the expectations of our customers, a standard of service they should expect.

## Quality

WBA is dedicated in providing the highest quality products and services to our customers with a commitment for continuous improvement. Increased quality in service and manufacturing will ensure positive results for your project. Our professional operations team employs the principles of lean manufacturing, and enterprise resource planning tools, all supported by our formal ISO 9001:2000, RC 14001 and AISC quality management systems.



**WWW.WBACORP.COM**  
**REPRESENTATIVE LOCATOR**

## WWW.WBACORP.COM

We are continually improving the Watson Bowman Acme website, enhancing your ability to easily navigate through our products and services. WBA has evolved over the years, but one priority has remained the same: to provide you with the accurate information you need, when you need it.



**Watson Bowman Acme Corp.**  
95 Pineview Drive Amherst, NY 14228  
Tel. 716.691.7566 | Fax 716.691.9239  
[www.wbacorp.com](http://www.wbacorp.com)

**BASF**  
The Chemical Company

© 2007 Watson Bowman Acme Corp.  
All rights reserved / Printed in USA  
POAS-BR-071011