

Architectural Products
Expansion Control Systems



INTRODUCING

Wabo® FireShield (FSH&FSV)

Fire barrier expansion control system

LIFE SAFETY AND EXPANSION CONTROL.
IT'S THE COMPLETE PACKAGE.

Multi-Functional, Fire Rated system that will accommodate a broad range of structural movement. For Life-Safety and Expansion Control, it's the complete package.

Wabo®FireShield is a second generation unified fire rated, sound attenuating, UV stable, thermal sealant system. The system features silicone faces on each side of a fire-retardant impregnated foam sealant. The silicone finish enhances the water resistant nature of the product and provides an aesthetic finish. Wabo®FireShield also has the ability to handle variations in joint size through incremental sizing. There is no drilling or modifying of the substrate required for installation.

FEATURES	BENEFITS
Fire Rated	Two or three hour fire rating in accordance with UL-2079
Sound Attenuation	Minimizes sound transfer
Ease of Installation	No mechanical anchors needed to install system. Saves time and labor
Generous Movement Capability	Can accommodate structural movement up to +/-50 and excellent for thin wall/slab applications



For our most current information,
please visit our website
@ wbacorp.com





Expansion & Contraction



Vertical Displacement



Expansion, Contraction & Vertical Displacement



Lateral Shear



Expansion, Contraction, Vertical Displacement & Lateral Shear



Fire Rated
(with added fire barrier system)



Water-Resistant



Water Proof



Color Choice
Elastomeric Seals



Available in Stainless
Steel or Aluminum



Meets ADA Guidelines



Light Cart



Fork Truck Traffic



Vehicle Traffic



Underwriters Laboratories
Listed Product

		Page #	Joint Opening	Movement	
Interior Wall & Ceiling		Wabo®FastWall	4	Up to 4"	
		Wabo®Contour	4	2" - 24"	
		Wabo®SeismicCover Interior WFT, WFI	5	4" - 24"	
		Wabo®FastWrap WC	6 - 7	Up to 4"	
		Wabo®FinishSeam	7 - 8	Up to 6"	
		Wabo®SeisMaxPlus NBW	9	4" - 24"	
		Wabo®FlatLine URG PRODUCT DISCONTINUED	9	Up to 2"	
Interior Floor		Wabo®Allure	10	Up to 6"	
		Wabo®SeisMaxPlus NBS	11	2" - 24"	
		Wabo®SeismicFloor	12 - 13	2" - 24"	
		Wabo®ConvexCover	14	Up to 4"	
		Wabo®SeismicPan	15	4" - 18"	
		Wabo®VIP	15	Up to 3"	
		Wabo®FastFloor	16 - 17	Up to 6"	
		Wabo®FastWrap Floor PRODUCT DISCONTINUED	18 - 19	Up to 3"	
		Wabo®HingeMount	20	2"-6"	
		Wabo®FlatLine URE PRODUCT DISCONTINUED	21	Up to 2"	
		Wabo®TwinSeam	21	2" - 6"	
Exterior Floor		Wabo®RoofCover	22	2" - 24"	
		Wabo®Flash	23	Up to 24"	
Exterior Wall		Wabo®Compression Seal	24	Up to 3"	
		Wabo®Seismic Cover WFX, WFE	25	6" - 24"	
		Wabo®WeatherSeal II	26	Up to 5"	
		Wabo®Seismic WeatherSeal	26	Up to 6"	
		Wabo®WeatherSeam	27	2" - 24"	
Fire Barrier		Wabo®FlameGuard I	28	Up to 12"	
		Wabo®FlameGuard II	29	Up to 12"	
		Wabo®FireFlex	30	Up to 20"	
		Wabo®ThermoShield	31	Up to 4"	

Wabo®FastWall



Wall-to-Wall/Ceiling-to-Ceiling

Model #	Joint Opening "A"		System Width "B"		Total Movement	
	in	mm	in	mm	in	mm
EWH-100	1.00	25	4.25	108	1.00	25.4
EWH-200	2.00	51	5.75	146	2.00	50.8
EWH-300	3.00	76	7.25	184	3.00	76.2
EWH-400	4.00	102	8.25	210	4.00	102

Wall-to-Corner/Ceiling-to-Corner

Model #	Joint Opening "A"		System Width "B"		Total Movement	
	in	mm	in	mm	in	mm
EWH-100C	1.00	25	2.88	73	1.00	25.4
EWH-200C	2.00	51	4.38	111	2.00	50.8
EWH-300C	3.00	76	5.88	149	3.00	76.2
EWH-400C	4.00	102	6.88	175	4.00	102

Wabo®Contour



Wall-to-Wall/Ceiling-to-Ceiling

Model #	Joint Opening "A"		System Width "B"		Total Movement	
	in	mm	in	mm	in	mm
CTR-200	2.00	51	8.63	219	4.00	102
CTR-400	4.00	102	13.63	346	7.00	178
CTR-600	6.00	152	15.63	397	7.00	178
CTR-800	8.00	203	20.75	527	8.00	203
CTR-1000	10.00	254	24.75	629	10.00	254
CTR-1200	12.00	305	28.75	730	12.00	305
CTR-1800	18.00	457	40.75	1035	18.00	457
CTR-2400	24.00	610	52.75	1340	24.00	610

Note: Contact WBA for larger sized joint openings and seismic systems

Wall-to-Corner/Ceiling-to-Corner

Model #	Joint Opening "A"		System Width "B"		Total Movement	
	in	mm	in	mm	in	mm
CTR-200C	2.00	51	4.75	121	3.00	25
CTR-400C	4.00	102	7.75	197	4.50	114
CTR-600C	6.00	152	10.75	273	4.50	114
CTR-800C	8.00	203	13.75	349	8.00	203
CTR-1000C	10.00	254	16.75	425	10.00	254
CTR-1200C	12.00	305	19.75	502	12.00	305
CTR-1800C	18.00	457	28.75	730	18.00	457
CTR-2400C	24.00	610	37.75	959	24.00	610

Note: Contact WBA for larger sized joint openings and seismic systems



FEATURES

- No visible hardware
- Surface Mounted
- Snap lock assembly
- Proven durability
- Quick & simple to install

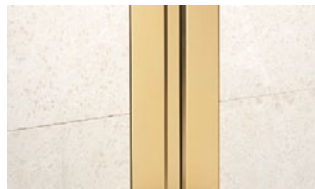
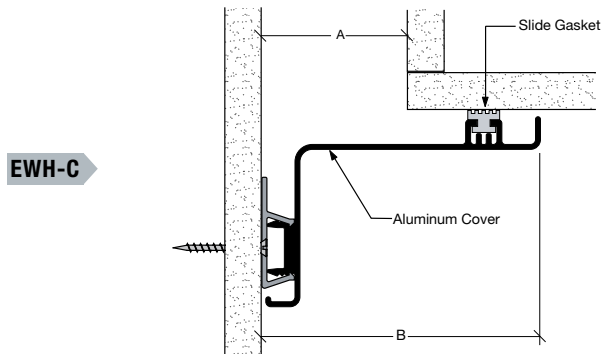
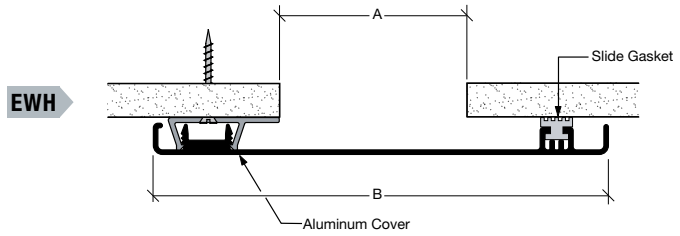

FEATURES

- Classic metal cover
- Installs flush with finish surfaces
- Multi-directional/ seismic
- Handles directional changes
- Color anodizing available

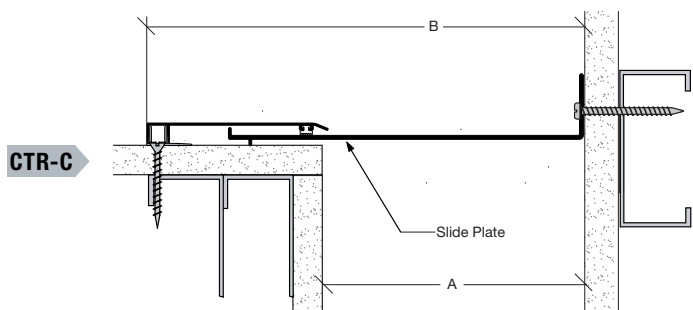
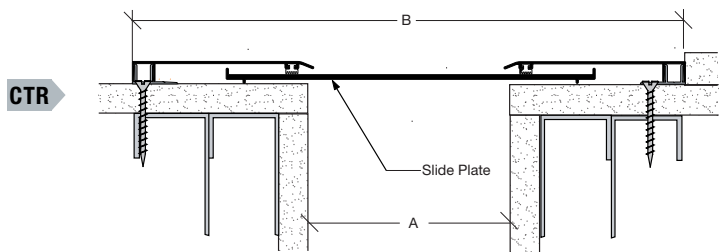

FEATURES

- Metal cover for wide openings
- Multi-directional/seismic movements
- Durable and vandal resistant
- Aluminum center plate
- Color anodizing available

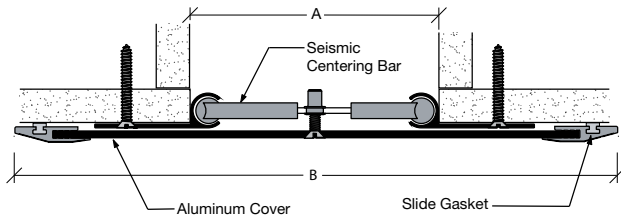
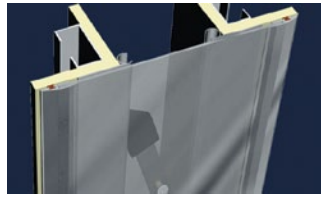

WFT

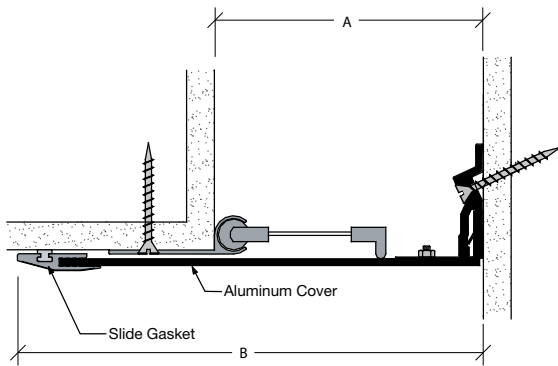

WFT-C

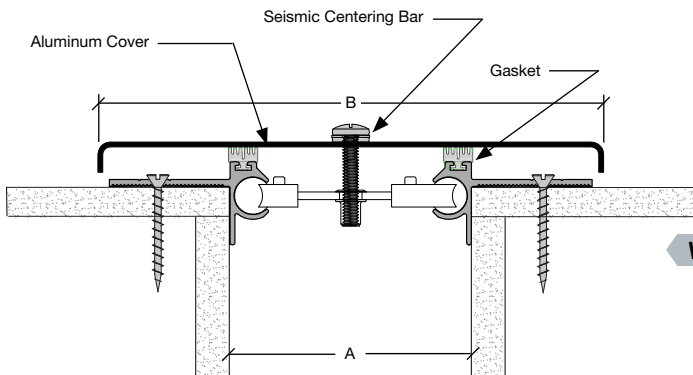

WFI

for WFI corner details, please visit our website at wbacorp.com

Wabo® SeismicCover WFT



Wall-to-Wall/Ceiling-to-Ceiling

Model #	Joint Opening "A"		System Width "B"		Total Movement	
	in	mm	in	mm	in	mm
WFT-400	4.00	102	13.50	343	9.75	248
WFT-600	6.00	152	13.50	343	9.75	248
WFT-800	8.00	203	17.50	445	13.75	349
WFT-1000	10.00	254	21.50	546	17.25	438
WFT-1200	12.00	305	25.50	648	21.00	533
WFT-1800	18.00	457	37.50	953	33.00	838
WFT-2400	24.00	610	49.50	1257	45.00	1143

Wall-to-Corner/Ceiling-to-Corner

Model #	Joint Opening "A"		System Width "B"		Total Movement	
	in	mm	in	mm	in	mm
WFT-400C	4.00	102	9.75	248	6.25	159
WFT-600C	6.00	152	9.75	343	6.25	248
WFT-800C	8.00	203	12.75	324	8.25	210
WFT-1000C	10.00	254	15.75	400	10.25	260
WFT-1200C	12.00	305	18.75	476	12.25	311
WFT-1800C	18.00	457	27.75	705	18.25	464
WFT-2400C	24.00	610	36.75	984	24.25	616

Wabo® SeismicCover WFI



Wall-to-Wall/Ceiling-to-Ceiling

Model #	Joint Opening "A"		System Width "B"		Total Movement	
	in	mm	in	mm	in	mm
WFI-200	2.00	51	6.38	162	3.00	76
WFI-400	4.00	102	8.38	213	6.00	152
WFI-600	6.00	152	11.38	289	9.00	229
WFI-800	8.00	203	14.38	365	12.00	305
WFI-1000	10.00	254	17.00	432	15.00	381
WFI-1200	12.00	305	19.75	502	18.00	457
WFI-1800	18.00	457	28.75	730	27.00	686
WFI-2400	24.00	610	37.75	959	36.00	914

Wall-to-Corner/Ceiling-to-Corner

Model #	Joint Opening "A"		System Width "B"		Total Movement	
	in	mm	in	mm	in	mm
WFI-200C	2.00	51	3.75	95	3.00	76
WFI-400C	4.00	102	6.75	171	6.00	152
WFI-600C	6.00	152	9.75	248	9.00	229
WFI-800C	8.00	203	12.75	324	12.00	305
WFI-1000C	10.00	254	15.88	403	9.75	248
WFI-1200C	12.00	305	18.88	479	11.75	299
WFI-1800C	18.00	457	27.88	708	17.75	451
WFI-2400C	24.00	610	36.88	937	23.75	603



Wabo®FastWrap WC



FEATURES

- Corridor wrap solution
- Narrow sight lines
- Flat seal
- Aluminum edge members
- Colorable elastomeric seals

MODELS CWS, CWF and CWC DISCONTINUED.

Please consult your WBA Representative for system replacement options

Wall-to-Wall/Ceiling-to-Ceiling

Replace with Model:	Model #	Joint Opening "A"		System Width "B"		Total Movement	
		in	mm	in	mm	in	mm
CWWF-200	CWS-200	2.00	51	2.00	51	0.75	19
CWWF-300	CWS-300	3.00	76	3.00	76	1.50	38

Wall-to-Wall/Ceiling-to-Ceiling

Replace with Model:	Model #	Joint Opening "A"		System Width "B"		Total Movement	
		in	mm	in	mm	in	mm
CWWS-200	CWF-200	2.00	51	2.00	51	0.75	19
CWWS-300	CWF-300	3.00	76	3.00	76	1.50	38

Wall-to-Corner/Ceiling-to-Corner

Replace with Model:	Model #	Joint Opening "A"		System Width "B"		Total Movement	
		in	mm	in	mm	in	mm
CWWS-200C	CWC-200	2.00	51	2.00	51	0.75	19
CWWS-300C	CWC-300	3.00	76	3.00	76	1.50	38

Ceiling-to-Ceiling

Model #	Joint Opening "A"		System Width "B"		Total Movement	
	in	mm	in	mm	in	mm
CES-100	1.00	25	2.00	51	1.00	25
CES-200	2.00	51	3.00	76	2.00	51

Ceiling-to-Ceiling

Model #	Joint Opening "A"		System Width "B"		Total Movement	
	in	mm	in	mm	in	mm
CEB-100	1.00	25	1.88	48	1.00	25
CEB-150	1.50	38	2.38	60	1.00	25
CEB-200	2.00	51	2.88	73	3.50	89
CEB-300	3.00	76	3.88	99	3.50	89
CEB-400	4.00	102	4.88	124	4.00	102

CWS

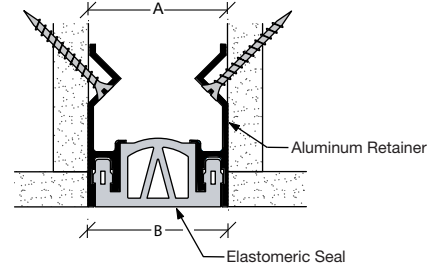

CWF

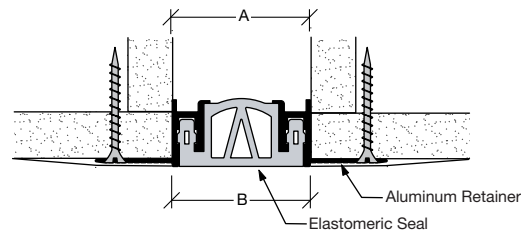

CWC

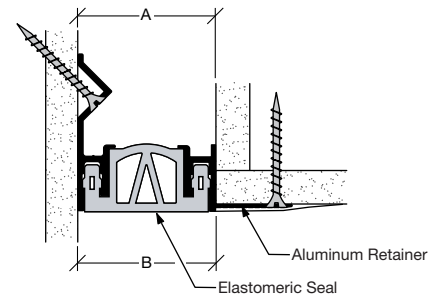

CES

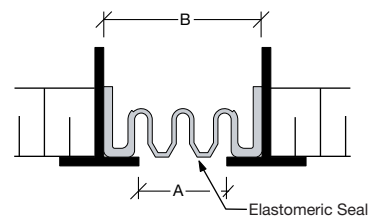

CEB

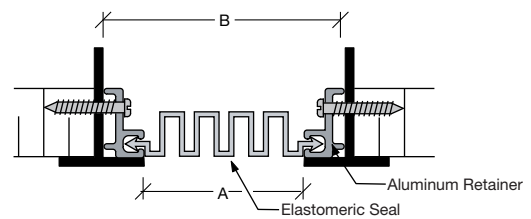

Wabo®FastWrap WC

(continued)

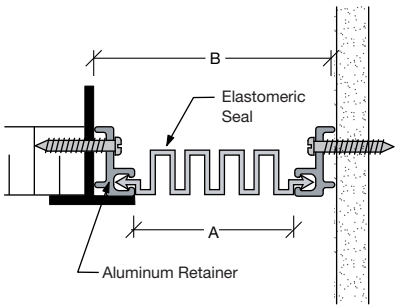

CEB-C

FEATURES

- Aesthetic sight-lines
- Handles complex directional changes
- Multi-directional movements
- No visible hardware or metal
- System width equal to opening
- Colorable elastomeric seals

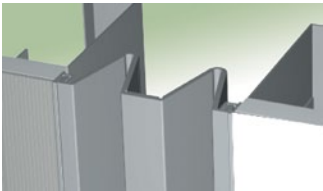

MODELS FSW, FSW-C, FSE, FSC and FSE DISCONTINUED.
 Please consult your WBA Representative for system replacement options

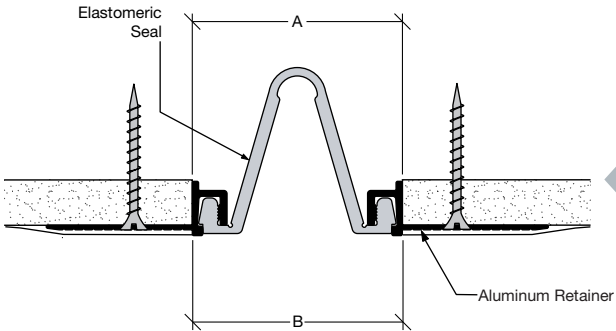

FSW

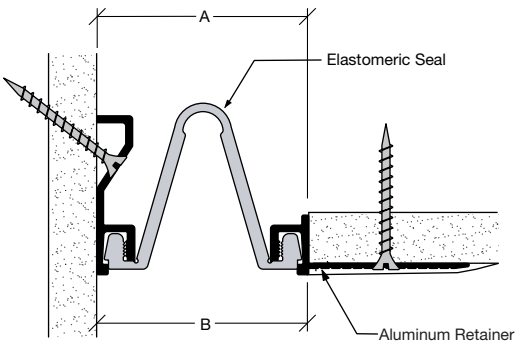

FSW-C

FSW-200 Seal Profile Shown - Visit www.wbacorp.com for profile configurations associated with other sized openings

Ceiling-to-Corner

Model #	Joint Opening "A"		System Width "B"		Total Movement	
	in	mm	in	mm	in	mm
CEB-100C	1.0	25	1.88	48	1.00	25
CEB-150C	1.5	38	2.38	60	1.00	25
CEB-200C	2.0	51	2.88	73	3.50	89
CEB-300C	3.0	76	3.88	99	3.50	89
CEB-400C	4.0	102	4.88	124	4.00	102

Wabo®FinishSeam



Wall-to-Wall/Ceiling-to-Ceiling

System Replaced by	Model #	Joint Opening "A"		System Width "B"		Total Movement	
		in	mm	in	mm	in	mm
CWWS	FSW-100	1.00	25	1.00	25	0.50	13
	FSW-200	2.00	51	2.00	51	2.00	51
	FSW-300	3.00	76	3.00	76	3.00	76
	FSW-400	4.00	102	4.00	102	4.00	102
	FSW-500	5.00	127	5.00	127	5.00	127
	FSW-600	6.00	152	6.00	152	6.00	152

Wall-to-Corner/Ceiling-to-Corner

System Replaced by	Model #	Joint Opening "A"		System Width "B"		Total Movement	
		in	mm	in	mm	in	mm
CWWS-C	FSW-100C	1.00	25	1.00	25	0.50	13
	FSW-200C	2.00	51	2.00	51	2.00	51
	FSW-300C	3.00	76	3.00	76	3.00	76
	FSW-400C	4.00	102	4.00	102	4.00	102
	FSW-500C	5.00	127	5.00	127	5.00	127
	FSW-600C	6.00	152	6.00	152	6.00	152

Wabo® FinishSeam

(continued)

Ceiling-to-Ceiling

System Replaced by	Model #	Joint Opening "A"		System Width "B"		Total Movement	
		in	mm	in	mm	in	mm
CWCA	FSC-100	1.00	25	0.75	18	0.50	13
	FSC-200	2.00	51	1.75	45	2.00	51
	FSC-300	3.00	76	2.75	70	3.00	76
	FSC-400	4.00	102	3.75	96	4.00	102
	FSC-500	5.00	127	4.75	121	5.00	127
	FSC-600	6.00	152	5.75	146	6.00	152

FSC

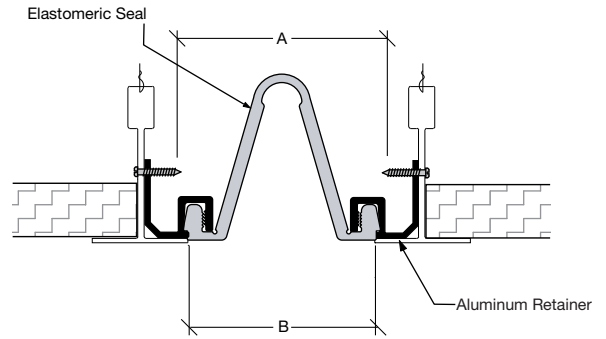

Ceiling-to-Corner

System Replaced by	Model #	Joint Opening "A"		System Width "B"		Total Movement	
		in	mm	in	mm	in	mm
CWCA-C	FSC-100C	1.00	25	0.75	18	0.50	13
	FSC-200C	2.00	51	1.75	45	2.00	51
	FSC-300C	3.00	76	2.75	70	3.00	76
	FSC-400C	4.00	102	3.75	96	4.00	102
	FSC-500C	5.00	127	4.75	121	5.00	127
	FSC-600C	6.00	152	5.75	146	6.00	152

FSC-C

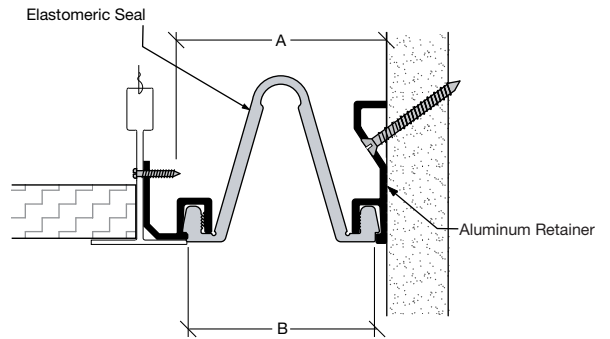

Wall-to-Wall/Ceiling-to-Ceiling

System Replaced by	Model #	Joint Opening "A"		System Width "B"		Total Movement	
		in	mm	in	mm	in	mm
CWWF	FSE-100	1.00	25	1.00	25	1.00	25
	FSE-200	2.00	51	2.00	51	2.00	51
	FSE-300	3.00	76	3.00	76	3.00	76
	FSE-400	4.00	102	4.00	102	4.00	102
	FSE-500	5.00	127	5.00	127	5.00	127
	FSE-600	6.00	152	6.00	152	6.00	152

FSE

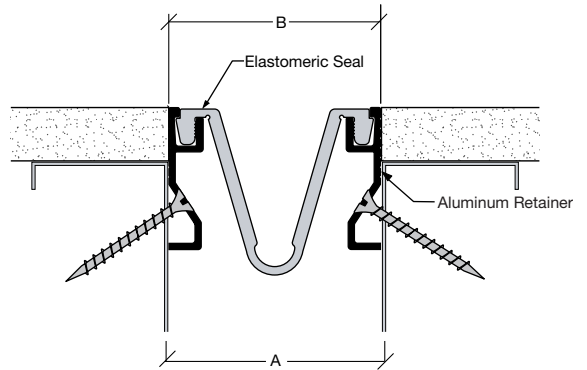

Wall-to-Corner/Ceiling-to-Corner

Model #	Joint Opening "A"		System Width "B"		Total Movement	
	in	mm	in	mm	in	mm
FSE-100C	1.00	25	1.00	25	1.00	25
FSE-200C	2.00	51	2.00	51	2.00	51
FSE-300C	3.00	76	3.00	76	3.00	76
FSE-400C	4.00	102	4.00	102	4.00	102
FSE-500C	5.00	127	5.00	127	5.00	127
FSE-600C	6.00	152	6.00	152	6.00	152

FSE-C

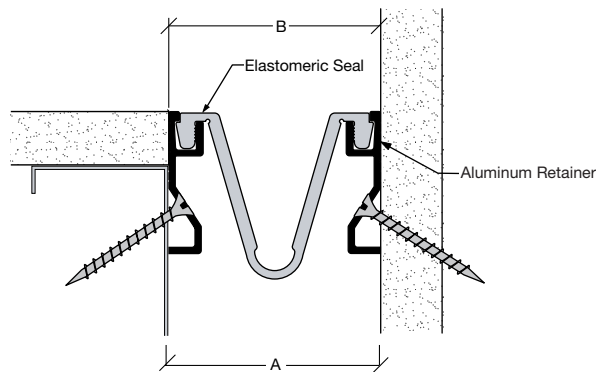

FSE-200 Seal Profile Shown - Visit www.wbacorp.com for profile configurations associated with other sized openings

FEATURES

- Twin seals offer more movement
- Accepts most wall finishes
- Multi-directional/seismic movements
- Seismic centering technology

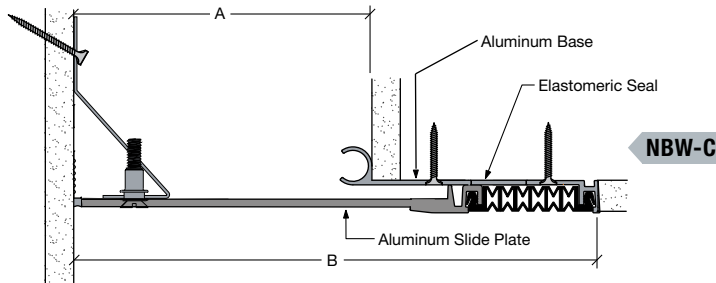
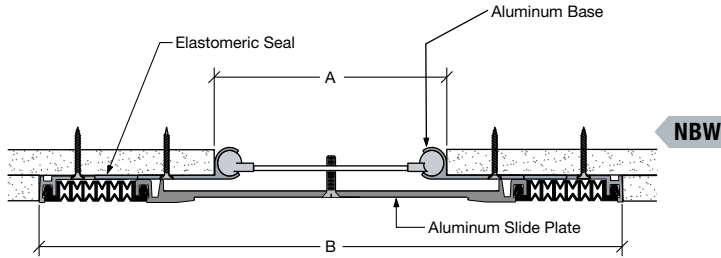
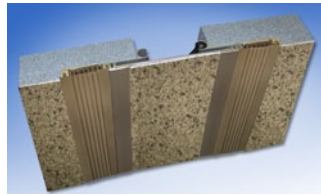

FEATURES

- Standard 10 ft. factory sections
- Aesthetically pleasing
- Narrow sight lines
- Factory bonded polyurethane
- Variety of standard & custom colors
- Wall systems handles 5/8" drywall

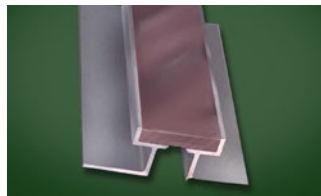

PRODUCT DISCONTINUED.

Please consult your WBA Representative for system replacement options

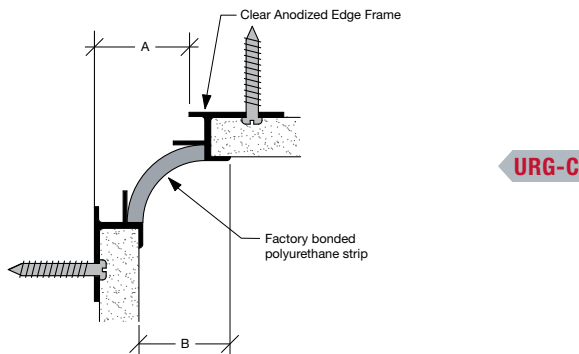
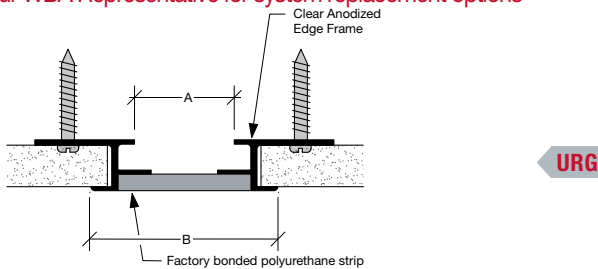

Wabo® SeisMaxPlus NBW



Wall-to-Wall/Ceiling-to-Ceiling

Model #	Joint Opening "A"		System Width "B"		Total Movement	
	in	mm	in	mm	in	mm
NBW-400	4.00	102	11.88	302	4.00	102
NBW-600	6.00	152	15.88	403	7.00	178
NBW-800	8.00	203	17.88	454	10.00	254
NBW-1000	10.00	254	21.88	556	13.00	330
NBW-1200	12.00	305	23.88	606	16.00	406
NBW-1800	18.00	457	33.88	860	25.00	635
NBW-2400	24.00	610	42.88	1089	34.00	864

Wall-to-Corner/Ceiling-to-Corner

Model #	Joint Opening "A"		System Width "B"		Total Movement	
	in	mm	in	mm	in	mm
NBW-400C	4.00	102	7.94	202	3.25	83
NBW-600C	6.00	152	10.94	278	5.75	146
NBW-800C	8.00	203	12.94	329	7.75	197
NBW-1000C	10.00	254	15.94	405	11.25	286
NBW-1200C	12.00	305	17.94	456	13.25	337
NBW-1800C	18.00	457	25.63	651	21.00	533
NBW-2400C	24.00	610	33.13	841	28.50	724

Wabo® FlatLine URG



Wall-to-Wall/Ceiling-to-Ceiling

System Replaced by	Model #	Joint Opening "A"		System Width "B"		Total Movement	
		in	mm	in	mm	in	mm
CWWS	URG-100	1.00	25	2.25	57	0.75	19.05
	URG-150	1.50	38	2.75	70	1.00	25.4
	URG-200	2.00	51	3.25	83	1.50	38.1

Wall-to-Corner/Ceiling-to-Corner

System Replaced by	Model #	Joint Opening "A"		System Width "B"		Total Movement	
		in	mm	in	mm	in	mm
CWWS-C	URG-100C	1.00	25	1.00	25	0.75	19.05
	URG-150C	1.50	38	1.50	38	1.00	25.4
	URG-200C	2.00	51	2.00	51	1.50	38.1



Wabo® Allure

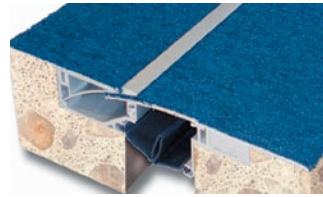

FEATURES

- Nearly invisible sight-line
- Multi-directional/seismic movements
- Flexible floor covering
- Quiet / no rattle leaf spring
- Airport terminal courtesy vehicles

Floor-to-Floor

Model #	Joint Opening "A"		System Width "B"		Total Movement	
	in	mm	in	mm	in	mm
AFJ-100	1.00	25	9.69	246	1.00	25
AFJ-200	2.00	51	9.69	246	2.00	51
AFJ-400	4.00	102	9.69	246	4.00	102
AFJ-600	6.00	152	13.63	346	6.00	152

Floor-to-Corner

Model #	Joint Opening "A"		System Width "B"		Total Movement	
	in	mm	in	mm	in	mm
AFJ-100C	1.00	25	7.31	186	1.00	25
AFJ-200C	2.00	51	7.31	186	2.00	51
AFJ-400C	4.00	102	7.31	186	4.00	102
AFJ-600C	6.00	152	11.25	286	6.00	152

AFJ

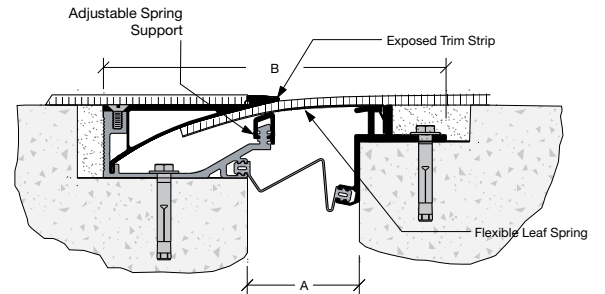

AFJ-C

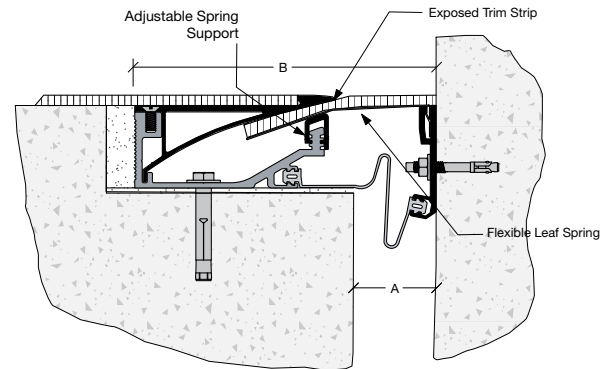

FEATURES

- Flush no-bump walking surface
- Twin seals offer more movement
- Accepts most finished flooring materials
- ADA compliant
- Multi-directional/seismic movements
- Seismic centering technology

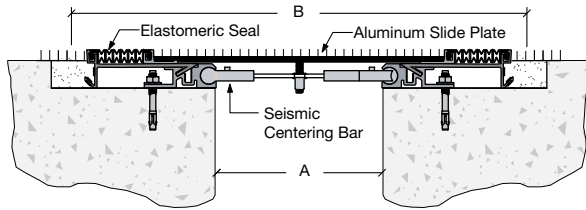
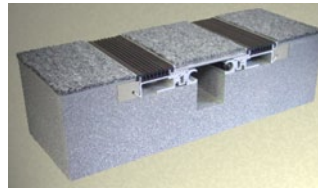

NBS

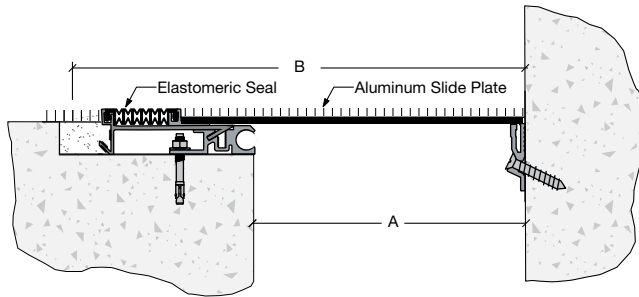

NBS-C

Wabo® SeisMaxPlus NBS



Floor-to-Floor

Model #	Joint Opening "A"		System Width "B"		Total Movement	
	in	mm	in	mm	in	mm
NBS-200	2.00	51	9.88	251	2.00	51
NBS-400	4.00	102	11.88	302	5.00	127
NBS-600	6.00	152	15.88	403	8.00	203
NBS-800	8.00	203	17.88	454	11.00	279
NBS-1000	10.00	254	21.88	556	14.00	356
NBS-1200	12.00	305	23.88	607	17.00	432
NBS-1800	18.00	457	33.88	861	26.00	660
NBS-2400	24.00	610	42.88	1089	35.00	889

Floor-to-Corner

Model #	Joint Opening "A"		System Width "B"		Total Movement	
	in	mm	in	mm	in	mm
NBS-200C	2.00	51	5.94	151	1.50	38
NBS-400C	4.00	102	7.94	202	3.50	89
NBS-600C	6.00	152	10.94	278	6.50	165
NBS-800C	8.00	203	12.94	329	8.50	216
NBS-1000C	10.00	254	15.94	405	7.75	197
NBS-1200C	12.00	305	17.94	456	8.75	222
NBS-1800C	18.00	457	25.69	653	14.00	356
NBS-2400C	24.00	610	33.19	843	18.25	464

Wabo® SeismicFloor



Floor-to-Floor

Model #	Joint Opening "A"		System Width "B"		Total Movement	
	in	mm	in	mm	in	mm
FJX-200	2.00	51	6.25	159	2.00	51
FJX-400	4.00	102	10.38	264	5.00	127
FJX-600	6.00	152	13.75	349	8.00	203
FJX-800	8.00	203	15.75	400	11.00	279
FJX-1000	10.00	254	18.75	476	14.00	356
FJX-1200	12.00	305	21.75	552	17.00	432
FJX-1800	18.00	457	31.75	806	26.00	660
FJX-2400	24.00	610	40.75	1035	35.00	889

Floor-to-Corner

Model #	Joint Opening "A"		System Width "B"		Total Movement	
	in	mm	in	mm	in	mm
FJX-200C	2.00	51	3.88	99	1.50	38
FJX-400C	4.00	102	7.19	183	4.00	102
FJX-600C	6.00	152	9.88	251	6.50	165
FJX-800C	8.00	203	11.88	302	9.00	229
FJX-1000C	10.00	254	14.38	365	11.50	292
FJX-1200C	12.00	305	16.88	429	14.00	356
FJX-1800C	18.00	457	24.88	632	21.50	546
FJX-2400C	24.00	610	32.38	822	29.00	737

Floor-to-Floor

Model #	Joint Opening "A"		System Width "B"		Total Movement	
	in	mm	in	mm	in	mm
FJG-200	2.00	51	5.75	146	2.00	51
FJG-400	4.00	102	10.38	264	5.00	127
FJG-600	6.00	152	13.75	349	8.00	203
FJG-800	8.00	203	15.75	400	11.00	279
FJG-1000	10.00	254	18.75	476	14.00	356
FJG-1200	12.00	305	21.75	552	17.00	432
FJG-1800	18.00	457	31.75	806	26.00	660
FJG-2400	24.00	610	40.75	1035	35.00	889

Floor-to-Corner

Model #	Joint Opening "A"		System Width "B"		Total Movement	
	in	mm	in	mm	in	mm
FJG-200C	2.00	51	3.88	99	1.50	38
FJG-400C	4.00	102	7.19	183	4.00	102
FJG-600C	6.00	152	9.88	251	6.50	165
FJG-800C	8.00	203	11.88	302	9.00	229
FJG-1000C	10.00	254	14.38	365	11.50	292
FJG-1200C	12.00	305	16.88	429	14.00	356
FJG-1800C	18.00	457	24.88	632	21.50	546
FJG-2400C	24.00	610	32.38	822	29.00	737

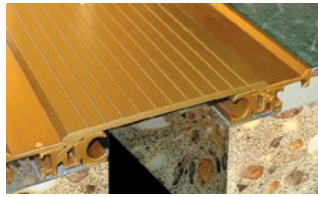

FEATURES

- Surface or Flush covers
- Seismic centering technology
- Multi-directional/seismic movements
- Aluminum, brass, or stainless
- ADA compliant

FJX

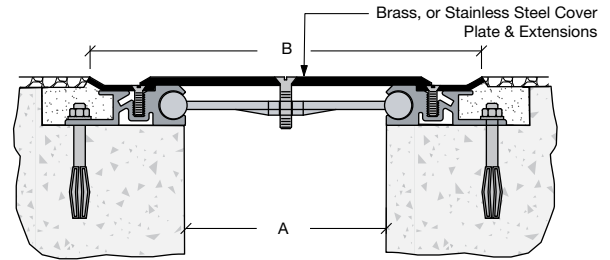

FJX-C

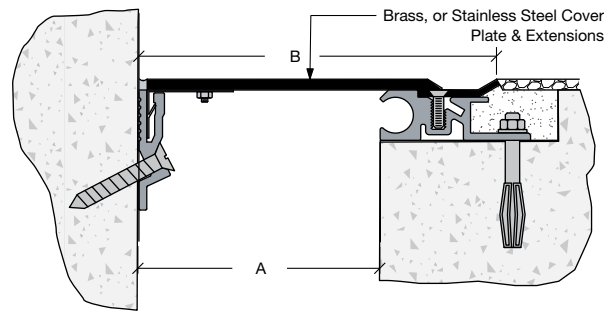

FJG

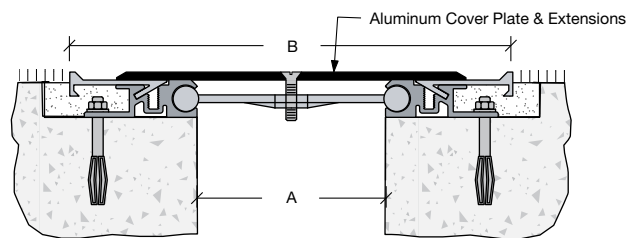

FJG-C

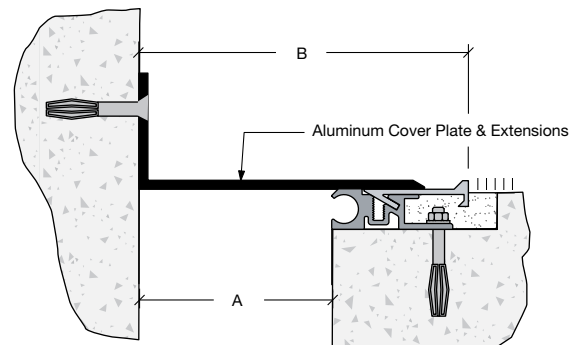

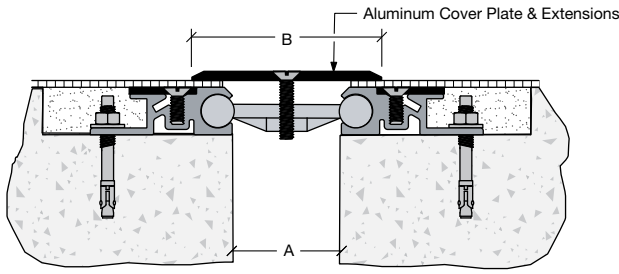

FJC

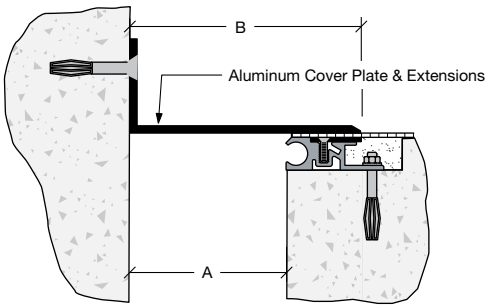

FJC-C

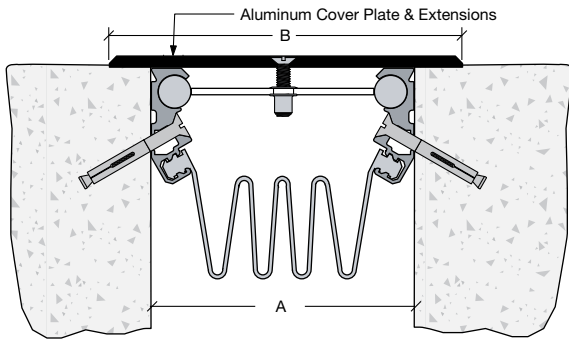

FXE

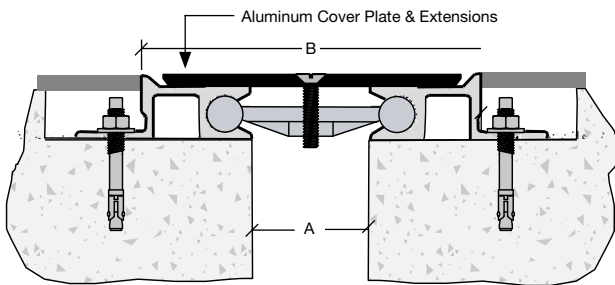

FNB

for FNB corner conditions, please visit our website at wbacorp.com

Floor-to-Floor

Model #	Joint Opening "A"		System Width "B"		Total Movement	
	in	mm	in	mm	in	mm
FJC-200	2.00	51	3.50	89	2.00	51
FJC-400	4.00	102	6.50	165	5.00	127
FJC-600	6.00	152	9.50	241	8.00	203
FJC-800	8.00	203	12.50	318	11.00	279
FJC-1000	10.00	254	15.50	394	14.00	356
FJC-1200	12.00	305	18.50	470	17.00	432
FJC-1800	18.00	457	27.50	699	26.00	660
FJC-2400	24.00	610	36.50	927	35.00	889

Floor-to-Corner

Model #	Joint Opening "A"		System Width "B"		Total Movement	
	in	mm	in	mm	in	mm
FJC-200C	2.00	51	2.75	70	1.50	38
FJC-400C	4.00	102	5.25	133	4.00	102
FJC-600C	6.00	152	7.75	197	6.50	165
FJC-800C	8.00	203	10.25	260	9.00	229
FJC-1000C	10.00	254	12.75	324	11.50	292
FJC-1200C	12.00	305	15.25	387	14.00	356
FJC-1800C	18.00	457	22.75	578	21.50	546
FJC-2400C	24.00	610	30.25	768	29.00	737

Floor-to-Floor

Model #	Joint Opening "A"		System Width "B"		Total Movement	
	in	mm	in	mm	in	mm
FXE-400	4.00	102	6.50	165	4.00	102
FXE-600	6.00	152	9.50	241	7.00	178
FXE-800	8.00	203	12.50	318	10.00	254
FXE-1000	10.00	254	15.50	394	13.00	330
FXE-1200	12.00	305	18.50	470	16.00	406
FXE-1800	18.00	457	27.50	699	25.00	635

Floor-to-Floor

Model #	Joint Opening "A"		System Width "B"		Total Movement	
	in	mm	in	mm	in	mm
FNB-200	2.00	51	5.75	146	2.00	51
FNB-300	3.00	76	7.75	197	5.00	127
FNB-400	4.00	102	7.75	197	5.00	127
FNB-500	5.00	127	11.75	171	8.00	203
FNB-600	6.00	152	11.75	171	8.00	203
FNB-800	8.00	203	15.19	386	11.00	279
FNB-1000	10.00	254	17.81	452	14.00	356
FNB-1200	12.00	305	20.81	529	17.00	432
FNB-1800	18.00	457	30.19	767	26.00	660
FNB-2400	24.00	610	37.19	945	34.50	876

Wabo® ConvexCover

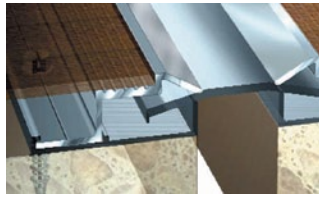

FEATURES

- Convex floating cover
- Handles vertical offset
- Attractive sight-line
- Snap-lock assembly
- ADA compliant

Floor-to-Floor

Model #	Joint Opening "A"		System Width "B"		Total Movement	
	in	mm	in	mm	in	mm
CCF-100	1.00	25	2.00	51	2.00	51
CCF-200	2.00	51	3.00	76	2.00	51
CCF-300	3.00	76	4.00	102	3.00	76
CCF-400	4.00	102	5.00	127	4.00	102

Floor-to-Corner

Model #	Joint Opening "A"		System Width "B"		Total Movement	
	in	mm	in	mm	in	mm
CCF-100C	1.00	25	1.50	38	1.00	25
CCF-200C	2.00	51	2.50	64	1.00	25
CCF-300C	3.00	76	3.50	89	2.30	57
CCF-400C	4.00	102	4.50	114	2.30	57

Floor-to-Floor

Model #	Joint Opening "A"		System Width "B"		Total Movement	
	in	mm	in	mm	in	mm
CCS-100	1.00	25	3.50	89	2.00	51
CCS-200	2.00	51	4.50	114	2.00	51
CCS-300	3.00	76	7.94	202	3.00	76
CCS-400	4.00	102	8.84	227	4.00	102

Floor-to-Corner

Model #	Joint Opening "A"		System Width "B"		Total Movement	
	in	mm	in	mm	in	mm
CCS-100C	1.00	25	2.25	57	1.00	25
CCS-200C	2.00	51	3.25	83	1.00	25
CCS-300C	3.00	76	5.50	140	2.30	57
CCS-400C	4.00	102	6.50	165	2.30	57

CCF

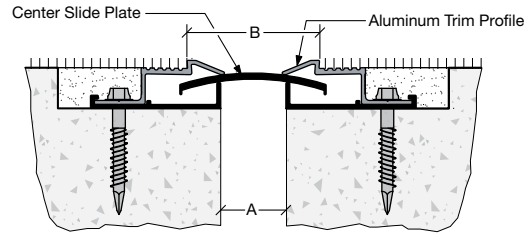

CCF-C

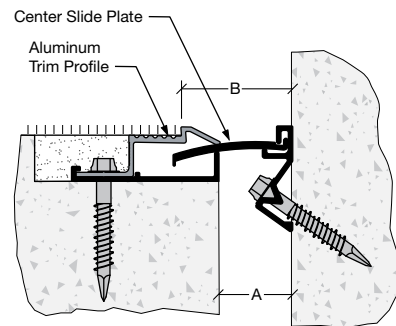

CCS

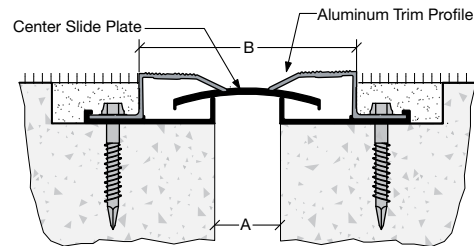

CCS-C

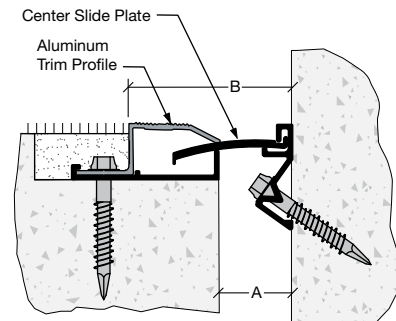

FEATURES

- Nearly invisible
- Flush walking surface
- Protects floors during earthquakes
- Multi-directional/seismic movements
- Can accept carpeting, pavers, tile, terrazzo, etc. flooring types
- Custom designs available

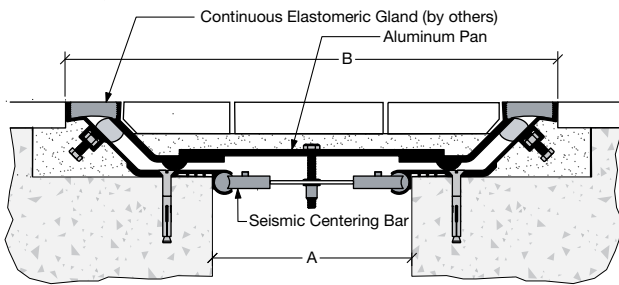
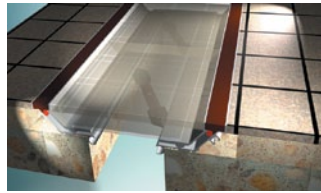

SPJ

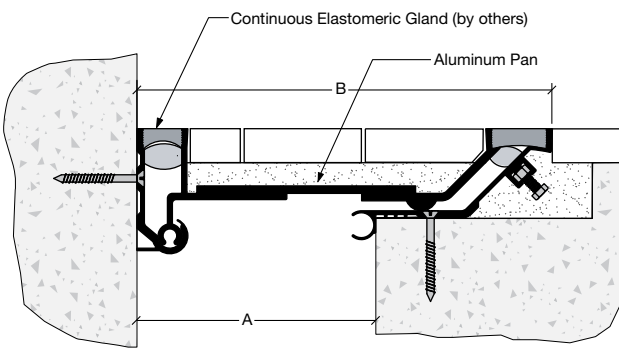

SPJ-C

FEATURES

- Beam support system
- Smooth no-bump riding surface
- High volume pedestrian traffic
- Money carts, courtesy vehicles
- Can accept terrazzo, tile, carpet, etc. flooring types
- Custom designs available

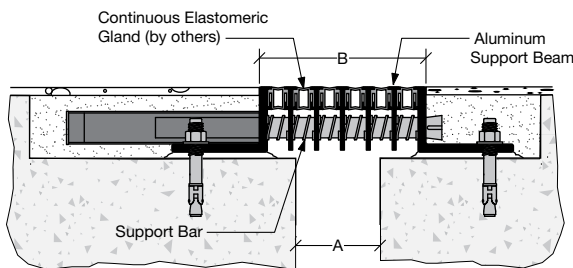
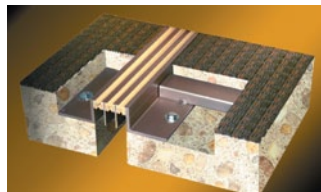

VIP

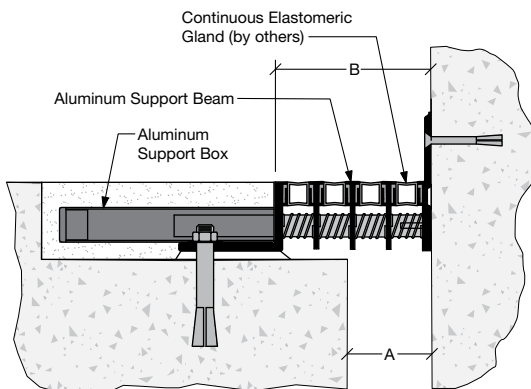

VIP-C

Wabo® SeismicPan



Floor-to-Floor

Model #	Joint Opening "A"		System Width "B"		Total Movement	
	in	mm	in	mm	in	mm
SPJ-400	4.00	102	12.88	327	4.75	121
SPJ-600	6.00	152	14.88	378	7.75	197
SPJ-800	8.00	203	18.88	480	10.75	273
SPJ-1000	10.00	254	20.88	530	13.75	349
SPJ-1200	12.00	305	23.88	607	16.75	425
SPJ-1600	16.00	406	29.88	759	22.75	578
SPJ-1800	18.00	457	34.88	886	25.75	654

Floor-to-Corner

Model #	Joint Opening "A"		System Width "B"		Total Movement	
	in	mm	in	mm	in	mm
SPJ-400C	4.00	102	8.44	214	3.00	76
SPJ-600C	6.00	152	10.44	265	5.50	140
SPJ-800C	8.00	203	13.44	341	8.00	203
SPJ-1000C	10.00	254	15.44	392	10.50	267
SPJ-1200C	12.00	305	17.94	456	13.00	330
SPJ-1600C	16.00	406	22.94	583	18.00	457
SPJ-1800C	18.00	457	26.44	672	20.50	521

Wabo® VIP



Floor-to-Floor

Model #	# Of Seals	Joint Opening "A"		System Width "B"		Total Movement	
		in	mm	in	mm	in	mm
VIP-750	2	0.75	19	2.00	51	0.75	19
VIP-1125	3	1.00	25	2.81	71	1.13	29
VIP-1500	4	1.50	38	3.63	92	1.50	38
VIP-1875	5	1.75	44	4.44	113	1.88	48
VIP-2250	6	2.00	51	5.25	133	2.25	57
VIP-2625	7	2.50	64	6.06	154	2.63	67
VIP-3000	8	3.00	76	6.88	175	3.00	76

Floor-to-Corner

Model #	# Of Seals	Joint Opening "A"		System Width "B"		Total Movement	
		in	mm	in	mm	in	mm
VIP-750C	2	0.75	19	2.00	51	0.75	19
VIP-1125C	3	1.00	25	2.81	71	1.13	29
VIP-1500C	4	1.50	38	3.63	92	1.50	38
VIP-1875C	5	1.75	44	4.44	113	1.88	48
VIP-2250C	6	2.00	51	5.25	133	2.25	57
VIP-2625C	7	2.50	64	6.06	154	2.63	67
VIP-3000C	8	3.00	76	6.88	175	3.00	76



Wabo®FastFloor



Floor-to-Floor

Model Replaced with	Model #	Joint Opening "A"		System Width "B"		Total Movement	
		in	mm	in	mm	in	mm
FJF	FFS-200	2.00	51	6.00	152	3.00	76
	FFS-400	4.00	102	8.00	203	5.00	127
	FFS-600	6.00	152	10.00	254	8.00	203

Floor-to-Corner

Model Replaced with	Model #	Joint Opening "A"		System Width "B"		Total Movement	
		in	mm	in	mm	in	mm
FJF-C	FFS-200C	2.00	51	4.00	102	2.63	67
	FFS-400C	4.00	102	6.00	152	4.63	118
	FFS-600C	6.00	152	8.00	203	7.13	181

Floor-to-Floor

Model Replaced with	Model #	Joint Opening "A"		System Width "B"		Total Movement	
		in	mm	in	mm	in	mm
FJF	FFR-200	2.00	51	7.25	184	3.00	76
	FFR-400	4.00	102	9.25	235	4.00	102
	FFR-600	6.00	152	11.25	286	4.00	102

Floor-to-Corner

Model Replaced with	Model #	Joint Opening "A"		System Width "B"		Total Movement	
		in	mm	in	mm	in	mm
FJF-C	FFR-200C	2.00	51	4.63	118	2.00	51
	FFR-400C	4.00	102	6.63	168	2.00	51
	FFR-600C	6.00	152	8.63	219	2.00	51

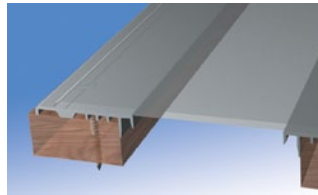

FEATURES

- Durable cover system
- No block-outs required
- Accepts most finished flooring
- Minimal components
- ADA compliant

MODELS FFS, FFS-C, FFR and FFR-C DISCONTINUED.
Please consult your WBA Representative for system replacement options

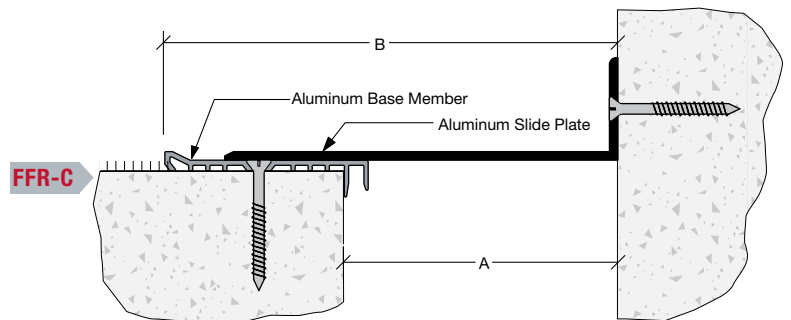
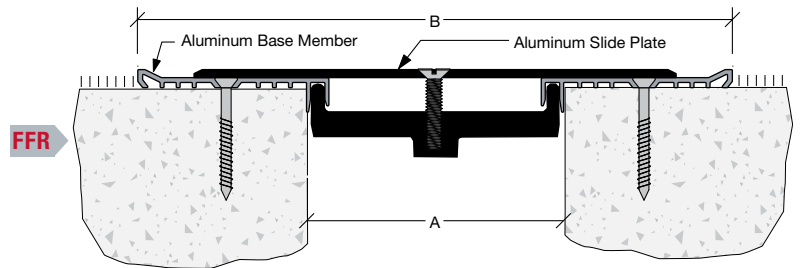
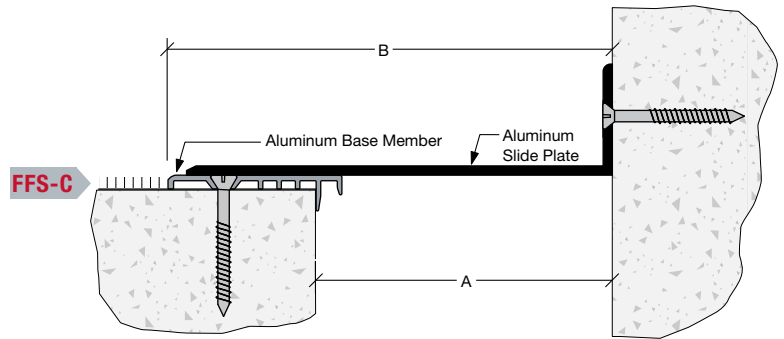
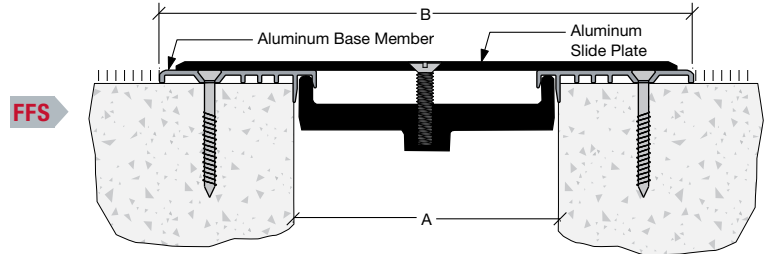

Wabo®FastFloor

(Continued)

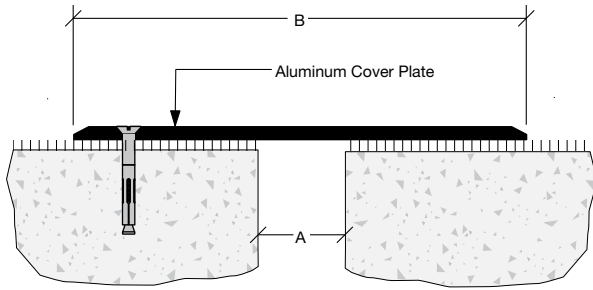

FJF

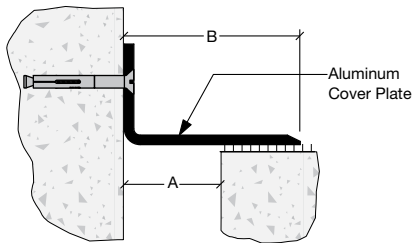

FJF-C

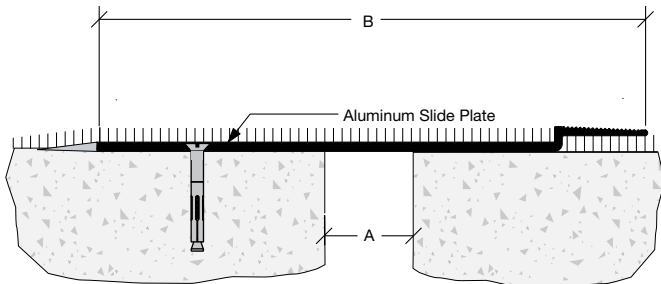

FJS

FJS Shown - Contact WBA for FJS-C availability

Floor-to-Floor

Model #	Joint Opening "A"		System Width "B"		Total Movement	
	in	mm	in	mm	in	mm
FJF-100	1.00	25	4.00	102	1.75	44
FJF-200	2.00	51	5.50	140	3.25	83
FJF-400	4.00	102	8.50	216	6.25	159
FJF-600	6.00	152	11.50	292	9.25	235

Floor-to-Corner

Model #	Joint Opening "A"		System Width "B"		Total Movement	
	in	mm	in	mm	in	mm
FJF-100C	1.00	25	2.00	51	1.75	44
FJF-200C	2.00	51	3.50	89	3.25	83
FJF-400C	4.00	102	6.50	165	6.25	159
FJF-600C	6.00	152	9.50	241	9.25	235

Floor-to-Floor

Model #	Joint Opening "A"		System Width "B"		Total Movement	
	in	mm	in	mm	in	mm
FJS-200.125	2.00	51	7.00	178	1.00	25
FJS-200.250	2.00	51	7.00	178	1.00	25
FJS-200.375	2.00	51	7.00	178	1.00	25

Note: Last three digits in model number denotes thickness of flooring material

Wabo®FastWrap Floor

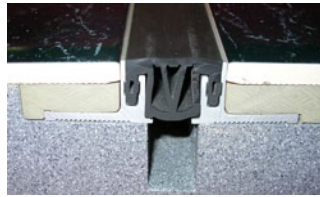

FEATURES

- Corridor wrap solution
- Narrow sight lines
- Flat seal / ADA compliant
- Aluminum edge members
- Colorable elastomeric seals

PRODUCT DISCONTINUED.

Please consult your WBA Representative for system replacement options

Floor-to-Floor

System Replaced by	Model #	Joint Opening "A"		System Width "B"		Total Movement	
		in	mm	in	mm	in	mm
CWFC-200	LPC-200	2.00	51	2.00	51	0.75	19
CWFC-300	LPC-300	3.00	76	3.00	76	1.50	38

Floor-to-Corner

System Replaced by	Model #	Joint Opening "A"		System Width "B"		Total Movement	
		in	mm	in	mm	in	mm
CWFC-200C	LPC-200C	2.00	51	2.00	51	0.75	19
CWFC-300C	LPC-300C	3.00	76	3.00	76	1.50	38

Floor-to-Floor

System Replaced by	Model #	Joint Opening "A"		System Width "B"		Total Movement	
		in	mm	in	mm	in	mm
CWFF-100	LPF-100	1.00	25	2.00	51	0.75	19
CWFF-200	LPF-200	2.00	51	3.00	76	1.50	38

Floor-to-Corner

System Replaced by	Model #	Joint Opening "A"		System Width "B"		Total Movement	
		in	mm	in	mm	in	mm
CWFF-100C	LPF-100C	1.00	25	2.00	51	0.75	19
CWFF-200C	LPF-200C	2.00	51	3.00	76	1.50	38

LPC

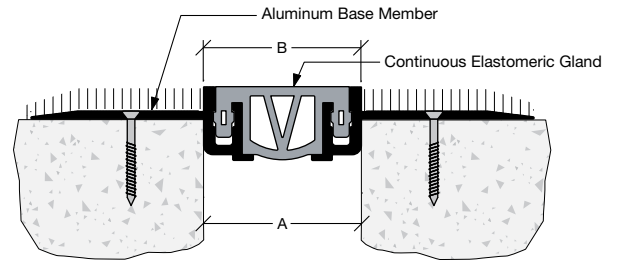

LPC-C

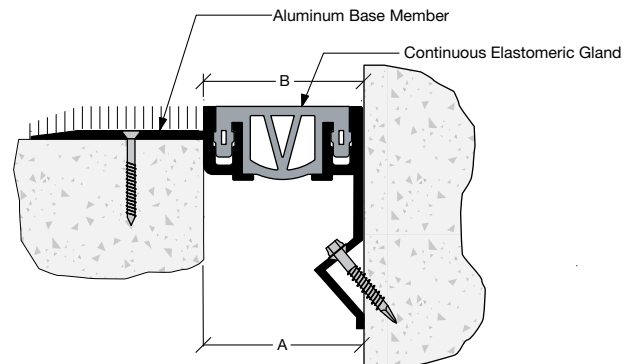

LPF

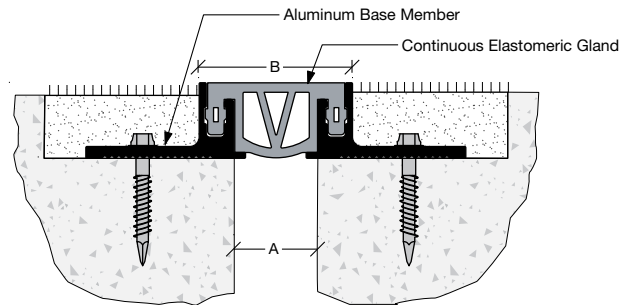

LPF-C

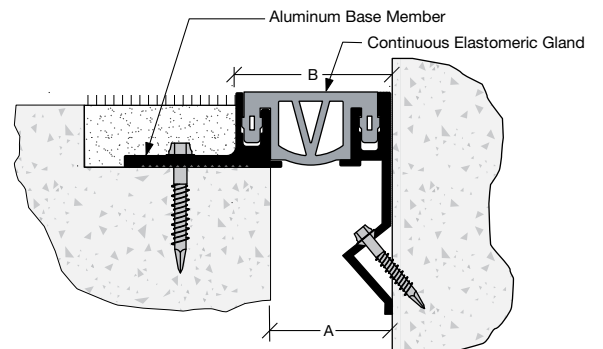

Wabo®FastWrap Floor

(Continued)

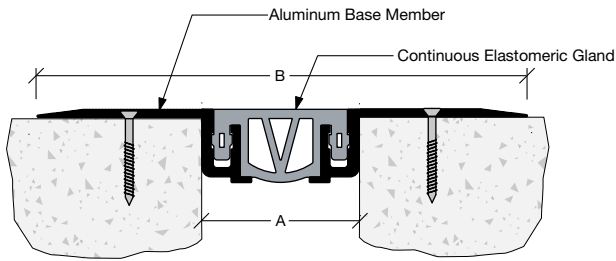

LPP

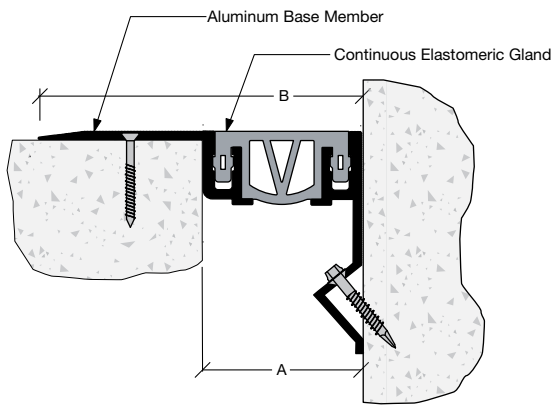

LPP-C

Floor-to-Floor

System Replaced by	Model #	Joint Opening "A"		System Width "B"		Total Movement	
		in	mm	in	mm	in	mm
CWFS-200	LPP-200	2.00	51	6.75	171	0.75	19
CWFS-300	LPP-300	3.00	76	7.75	197	1.50	38

Floor-to-Corner

System Replaced by	Model #	Joint Opening "A"		System Width "B"		Total Movement	
		in	mm	in	mm	in	mm
CWFS-200C	LPP-200C	2.00	51	4.38	111	0.75	19
CWFS-300C	LPP-300C	3.00	76	5.38	137	1.50	38

Wabo® HingeMount

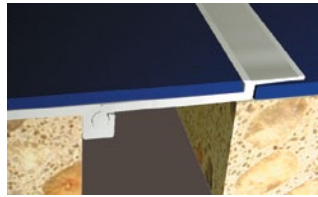

FEATURES

- Integral hinge feature
- No block-outs required
- Ideal for retrofit projects
- Handles 1-1/2" vertical offset

Floor-to-Floor

Model #	Joint Opening "A"		System Width "B"		Total Movement	
	in	mm	in	mm	in	mm
FJH-200.125	2.00	51	13.25	337	1.00	25
FJH-200.250	2.00	51	13.25	337	1.00	25
FJH-200.375	2.00	51	13.25	337	1.00	25

Note: Last three digits in model number denotes thickness of flooring material

Floor-to-Corner

Model #	Joint Opening "A"		System Width "B"		Total Movement	
	in	mm	in	mm	in	mm
FJH-200.125C	2.00	51	7.31	186	1.00	25
FJH-200.250C	2.00	51	7.31	186	1.00	25
FJH-200.375C	2.00	51	7.31	186	1.00	25

Note: Last three digits in model number denotes thickness of flooring material

Floor-to-Floor

Model #	Joint Opening "A"		System Width "B"		Total Movement	
	in	mm	in	mm	in	mm
HDH-200	2.00	51	8.00	203	2.00	51
HDH-300	3.00	76	13.13	334	2.00	51
HDH-600	6.00	152	16.63	422	2.00	51

Floor-to-Corner

Model #	Joint Opening "A"		System Width "B"		Total Movement	
	in	mm	in	mm	in	mm
HDH-200C	2.00	51	4.00	102	1.50	38
HDH-300C	3.00	76	7.25	184	2.50	64
HDH-600C	6.00	152	9.69	246	3.00	76

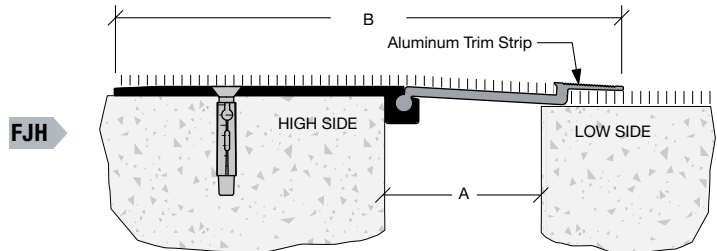

FJH

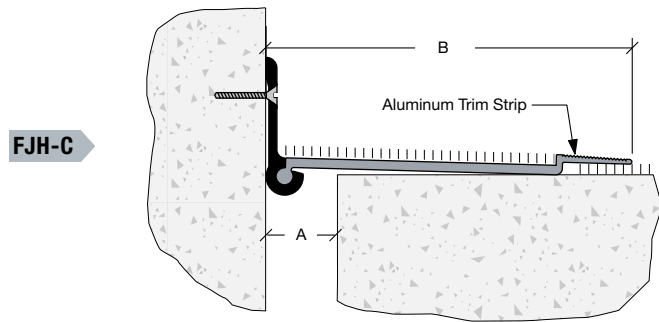

FJH-C

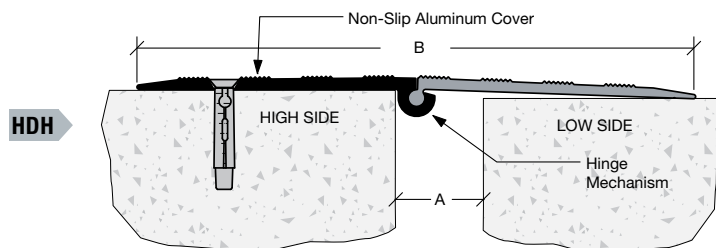

HDH

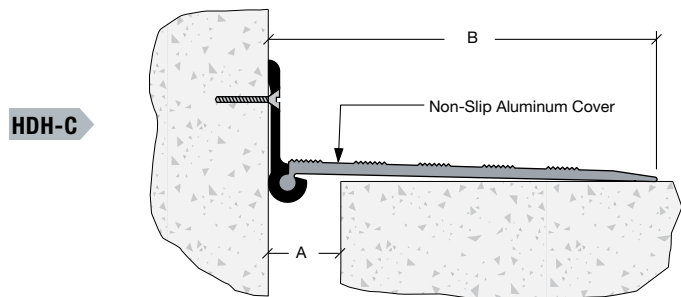

HDH-C

FEATURES

- Standard 10 ft. factory sections
- Aesthetically pleasing
- Narrow sight lines
- Factory bonded polyurethane
- Variety of standard & custom colors

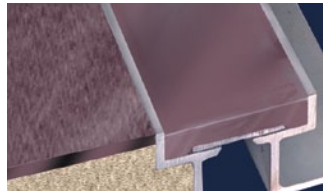

PRODUCT DISCONTINUED.

Please consult your WBA Representative for system replacement options

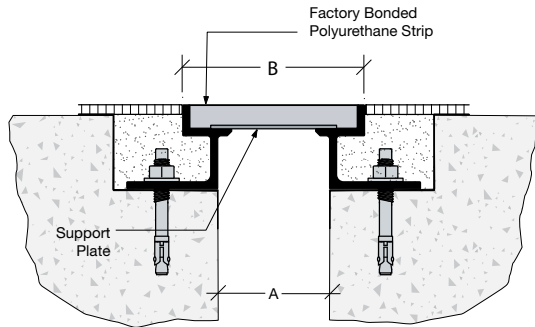

URE

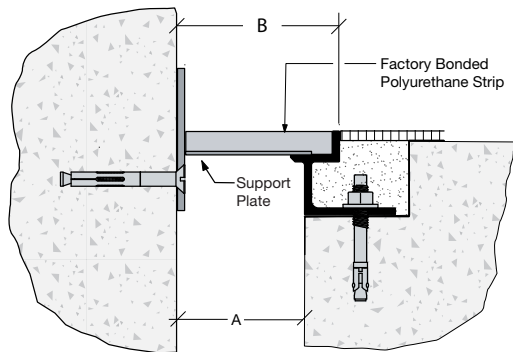

URE-C

FEATURES

- Aesthetically pleasing
- No visible hardware
- No block-outs required
- Flat seal design
- Accepts most finished flooring
- Also suggested for vertical gyp. board applications

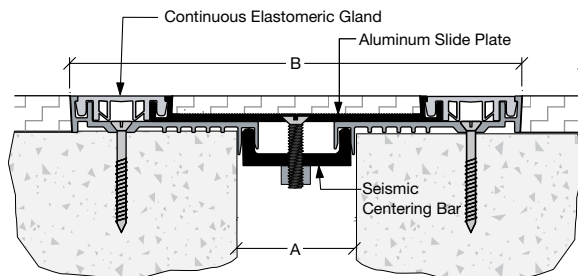

TSF

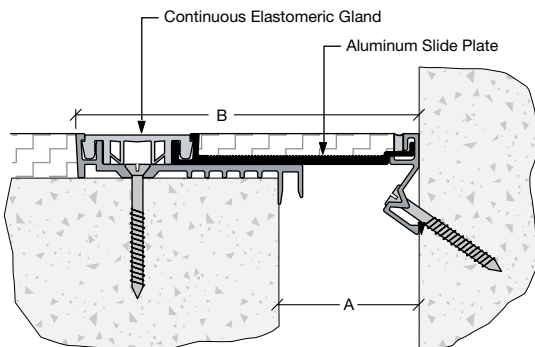

TSF-C

Wabo® FlatLine URE



Floor-to-Floor

System Replaced by	Model #	Joint Opening "A"		System Width "B"		Total Movement	
		in	mm	in	mm	in	mm
CWFF-100	URE-100	1.00	25	2.25	57	0.75	19
CWFF-200	URE-150	1.50	38	2.75	70	1.00	25
CWFF-300	URE-200	2.00	51	3.25	83	1.50	38

Floor-to-Corner

System Replaced by	Model #	Joint Opening "A"		System Width "B"		Total Movement	
		in	mm	in	mm	in	mm
CWFF-100C	URE-100C	1.00	25	1.63	41	0.75	19
CWFF-200C	URE-150C	1.50	38	2.13	54	1.00	25
CWFF-300C	URE-200C	2.00	51	2.63	67	1.50	38

Wabo® TwinSeam



Floor-to-Floor

Model #	Joint Opening "A"		System Width "B"		Total Movement	
	in	mm	in	mm	in	mm
TSF-200	2.00	51	7.75	197	4.25	108
TSF-400	4.00	102	9.75	248	6.25	159
TSF-600	6.00	152	11.75	298	8.25	210

Floor-to-Corner

Model #	Joint Opening "A"		System Width "B"		Total Movement	
	in	mm	in	mm	in	mm
TSF-200C	2.00	51	4.88	124	2.50	64
TSF-400C	4.00	102	6.88	175	4.50	114
TSF-600C	6.00	152	8.88	225	6.50	165



Wabo® RoofCover



Roof-to-Roof

Model #	Joint Opening "A"		System Width "B"		Total Movement	
	in	mm	in	mm	in	mm
RFL-200	2.00	51	8.00	203	3.00	76
RFL-400	4.00	102	11.00	279	6.00	152
RFL-600	6.00	152	14.00	356	9.00	229
RFL-800	8.00	203	17.00	432	12.00	305
RFL-1000	10.00	254	20.00	508	15.00	381
RFL-1200	12.00	305	23.00	584	18.00	457
RFL-1800	18.00	457	32.00	813	27.00	686
RFL-2400	24.00	610	41.00	1041	36.00	914

Roof-to-Corner

Model #	Joint Opening "A"		System Width "B"		Total Movement	
	in	mm	in	mm	in	mm
RFL-200C	2.00	51	5.50	140	3.00	76
RFL-400C	4.00	102	8.50	216	6.00	152
RFL-600C	6.00	152	11.50	292	9.00	229
RFL-800C	8.00	203	14.50	368	12.00	305
RFL-1000C	10.00	254	17.50	445	9.75	248
RFL-1200C	12.00	305	20.50	521	11.75	298
RFL-1800C	18.00	457	29.50	749	17.75	451
RFL-2400C	24.00	610	38.50	978	23.75	603

Roof-to-Roof

Model #	Joint Opening "A"		System Width "B"		Total Movement	
	in	mm	in	mm	in	mm
RFC-200	2.00	51	6.40	163	3.00	76
RFC-400	4.00	102	8.40	213	6.00	152
RFC-600	6.00	152	11.40	290	9.00	229
RFC-800	8.00	203	14.40	366	12.00	305
RFC-1000	10.00	254	17.00	432	15.00	381
RFC-1200	12.00	305	19.80	502	18.00	457
RFC-1800	18.00	457	28.80	732	27.00	686
RFC-2400	24.00	610	37.80	960	36.00	914

Roof-to-Corner

Model #	Joint Opening "A"		System Width "B"		Total Movement	
	in	mm	in	mm	in	mm
RFC-200C	0.00	0	3.80	95	3.00	76
RFC-400C	0.00	0	6.80	171	6.00	152
RFC-600C	0.00	0	9.80	248	9.00	229
RFC-800C	0.00	0	12.80	324	12.00	305
RFC-1000C	5.30	133	15.90	404	9.75	248
RFC-1200C	6.30	159	18.90	480	11.75	298
RFC-1800C	9.30	235	27.90	709	17.75	451
RFC-2400C	12.30	311	36.90	937	23.75	603



FEATURES

- Water resistant
- Proven durability
- Puncture proof
- Handles snow and ice loads
- Flat or sloped roofs

RFL

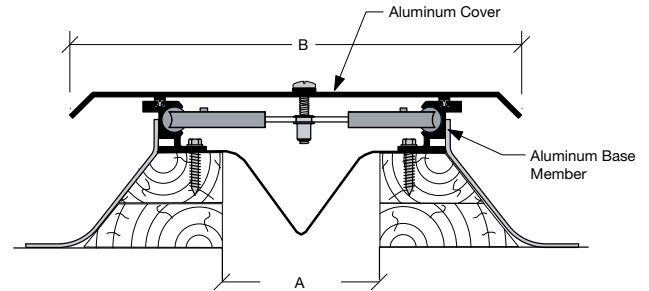

RFL-C

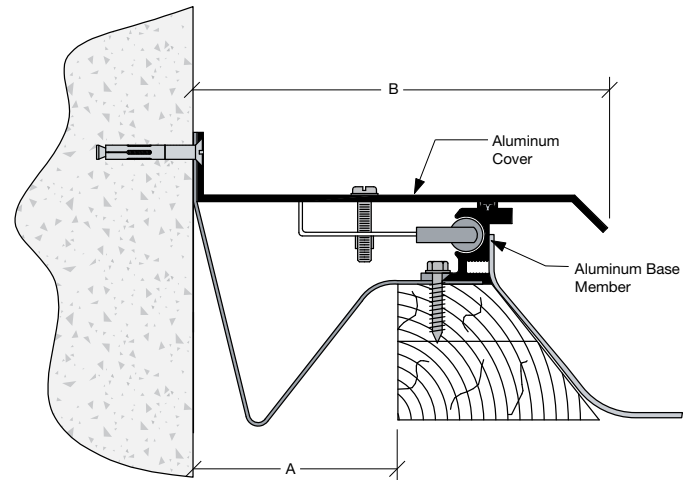

RFC

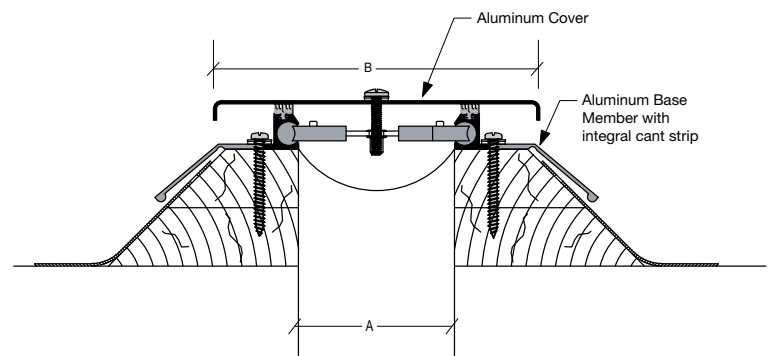

RFC-C

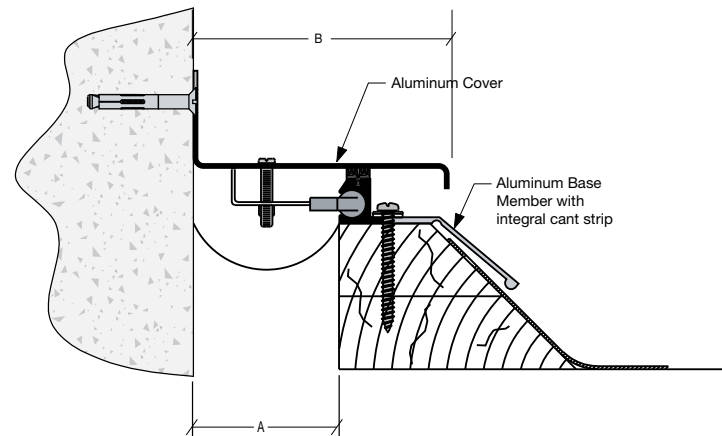

FEATURES

- For exterior walls & roofs
- Flexible expanded rubber with membrane
- Complex directional changes
- Integral metal flanges

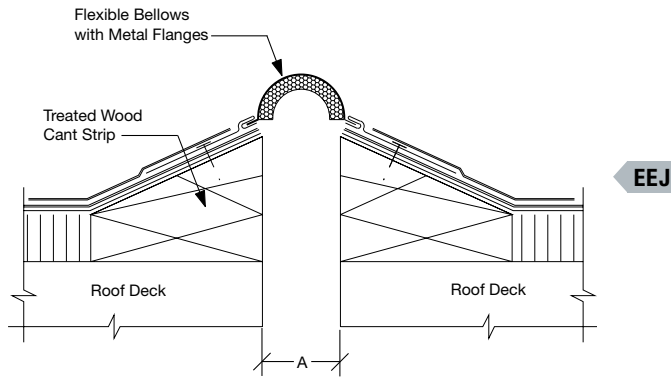
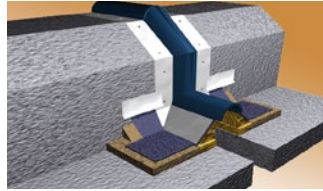

EEJ

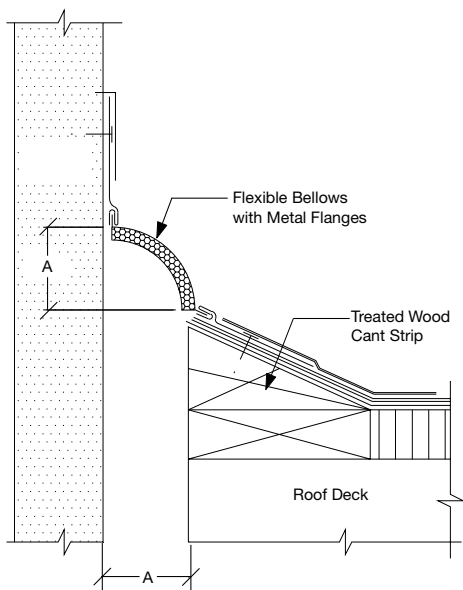

EEJ-C

Wabo® Flash



Roof-to-Roof

Model #	Joint Opening "A" (@mid)		Total Movement	
	in	mm	in	mm
EEJ-100	1.00	25	1.00	25
EEJ-200	2.00	51	2.00	51
EEJ-300	3.00	76	3.00	76
EEJ-400	4.00	102	4.00	102
EEJ-500	5.00	127	5.00	127
EEJ-600	6.00	152	6.00	152
EEJ-700	7.00	178	7.00	178
EEJ-800	8.00	203	8.00	203
EEJ-1000	10.00	254	10.00	254
EEJ-1200	12.00	305	12.00	305
EEJ-1600	16.00	406	16.00	406
EEJ-1800	18.00	457	18.00	457
EEJ-2000	20.00	508	20.00	508
EEJ-2400	24.00	610	24.00	610

Roof-to-Corner

Model #	Joint Opening "A" (@mid)		Total Movement	
	in	mm	in	mm
EEJ-100C	1.00	25	1.00	25
EEJ-200C	2.00	51	2.00	51
EEJ-300C	3.00	76	3.00	76
EEJ-400C	4.00	102	4.00	102
EEJ-500C	5.00	127	5.00	127
EEJ-600C	6.00	152	6.00	152
EEJ-700C	7.00	178	7.00	178
EEJ-800C	8.00	203	8.00	203
EEJ-1000C	10.00	254	10.00	254
EEJ-1200C	12.00	305	12.00	305
EEJ-1600C	16.00	406	16.00	406
EEJ-1800C	18.00	457	18.00	457
EEJ-2000C	20.00	508	20.00	508
EEJ-2400C	24.00	610	24.00	610

Wabo® CompressionSeal

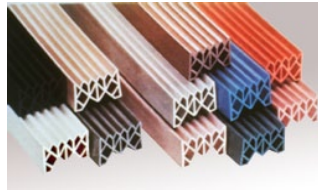

FEATURES

- Flexibility
- Versatility
- Colorable
- Durable & time tested

Slab-to-Slab

Model #	Joint Opening "A"						Installation Width		Groove Depth "B"	
	Min		Max		Total					
	in	mm	in	mm	in	mm	in	mm	in	mm
WE-100*	0.50	13	1.50	38	1.00	25	1.00	25	N/A	N/A
WE-225	0.69	17	1.94	49	1.25	32	1.38	35	1.88	48
WE-250	1.06	27	2.13	54	1.06	27	1.63	41	2.38	60
WE-300	1.25	32	2.56	65	1.31	33	2.00	51	2.53	64
WE-400	1.25	32	3.38	86	2.13	54	2.38	60	3.19	81
WE-500	1.44	37	4.25	108	2.81	71	2.88	73	3.63	92
WE-600	1.81	46	5.13	130	3.31	84	3.50	89	4.63	117

**Note: WE-100 not recommended for horizontal applications*

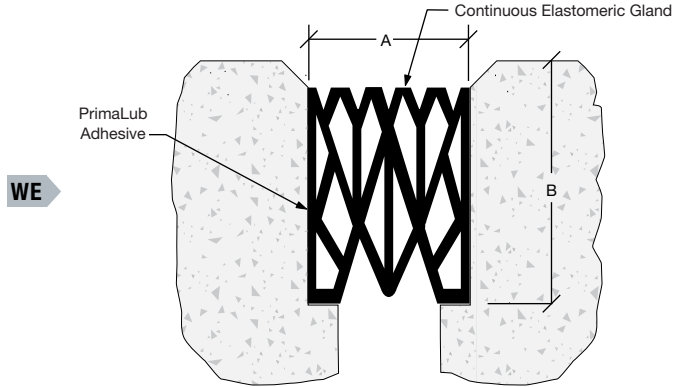

FEATURES

- Metal cover for wide openings
- Multi-directional/seismic
- Durable and vandal resistant
- Aluminum, brass, and stainless center plate
- Color anodizing available

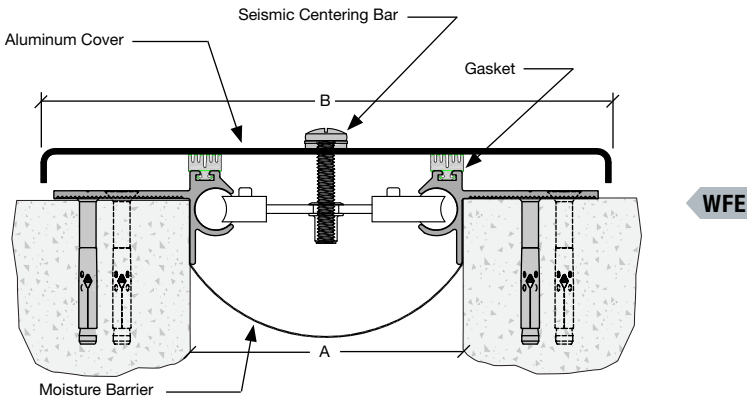
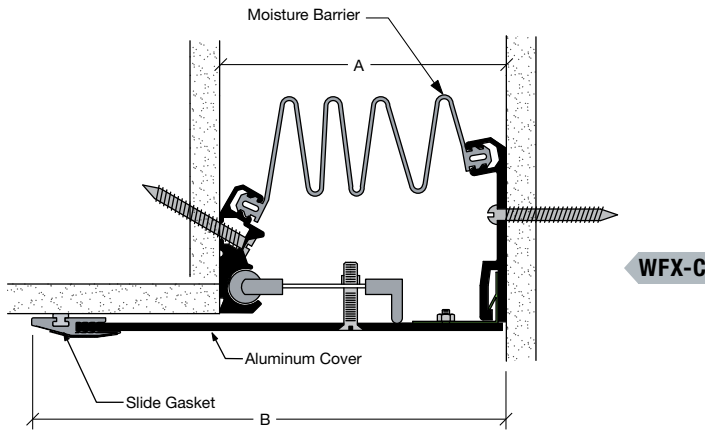
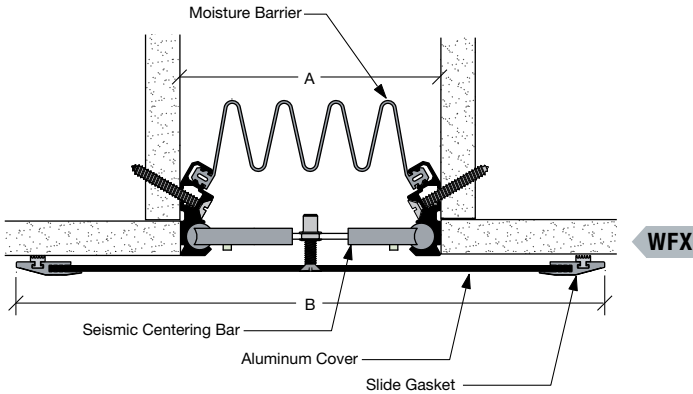
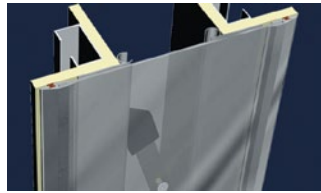

Wabo® SeismicCover WFX



Wall-to-Wall/Ceiling-to-Ceiling

Model #	Joint Opening "A"		System Width "B"		Total Movement	
	in	mm	in	mm	in	mm
WFX-600	6.00	152	13.50	343	9.75	248
WFX-800	8.00	203	17.50	445	13.75	349
WFX-1000	10.00	254	21.50	546	17.25	438
WFX-1200	12.00	305	25.50	648	21.00	533
WFX-1800	18.00	457	37.50	953	33.00	838
WFX-2400	24.00	610	49.50	1257	45.00	1143

Wall-to-Corner/Ceiling-to-Corner

Model #	Joint Opening "A"		System Width "B"		Total Movement	
	in	mm	in	mm	in	mm
WFX-600C	6.00	152	9.75	248	6.25	159
WFX-800C	8.00	203	12.75	324	8.25	210
WFX-1000C	10.00	254	15.75	400	10.25	260
WFX-1200C	12.00	305	18.75	476	12.25	311
WFX-1800C	18.00	457	27.75	705	18.25	464
WFX-2400C	24.00	610	36.75	984	24.25	616

Wabo® SeismicCover WFE



Wall-to-Wall/Ceiling-to-Ceiling

Model #	Joint Opening "A"		System Width "B"		Total Movement	
	in	mm	in	mm	in	mm
WFE-200	2.00	51	6.38	162	3.00	76
WFE-400	4.00	102	8.38	213	6.00	152
WFE-600	6.00	152	11.38	289	9.00	229
WFE-800	8.00	203	14.38	365	12.00	305
WFE-1000	10.00	254	17.00	432	15.00	381
WFE-1200	12.00	305	19.75	502	18.00	457
WFE-1800	18.00	457	28.75	730	27.00	686
WFE-2400	24.00	610	37.75	959	36.00	914

Wall-to-Corner/Ceiling-to-Corner

Model #	Joint Opening "A"		System Width "B"		Total Movement	
	in	mm	in	mm	in	mm
WFE-200C	2.00	51	3.75	95	3.00	76
WFE-400C	4.00	102	6.75	171	6.00	152
WFE-600C	6.00	152	9.75	248	9.00	229
WFE-800C	8.00	203	12.75	324	12.00	305
WFE-1000C	10.00	254	15.88	403	9.75	248
WFE-1200C	12.00	305	18.88	479	11.75	299
WFE-1800C	18.00	457	27.88	708	17.75	451
WFE-2400C	24.00	610	36.88	937	23.75	603

for WFE corner details, please visit our website at wbacorp.com



Wabo® WeatherSeal II



Wall-to-Wall

Model #	Joint Opening "A"						System Depth "B"	
	Min		Max		Total		in	mm
	in	mm	in	mm	in	mm		
WS-100	0.75	19	1.25	32	0.50	13	1.50	38
WS-150	1.13	29	1.88	48	0.75	19	2.00	51
WS-200	1.50	38	2.50	64	1.00	25	2.00	51
WS-250	1.88	48	3.13	80	1.25	32	2.00	51
WS-300	2.25	57	3.75	95	1.50	38	2.50	64
WS-350	2.63	67	4.38	111	1.75	44	2.50	64
WS-400	3.00	76	5.00	127	2.00	51	2.50	64
WS-500	3.75	95	6.25	159	2.50	64	4.00	102

Note: Other sizes are available. Contact WBA for details.

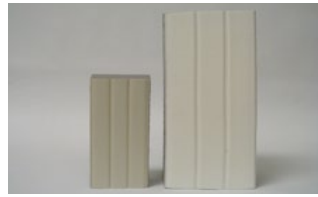

FEATURES

- Versatile movement +/-25%
- Ease of installation
- Colorable

WS

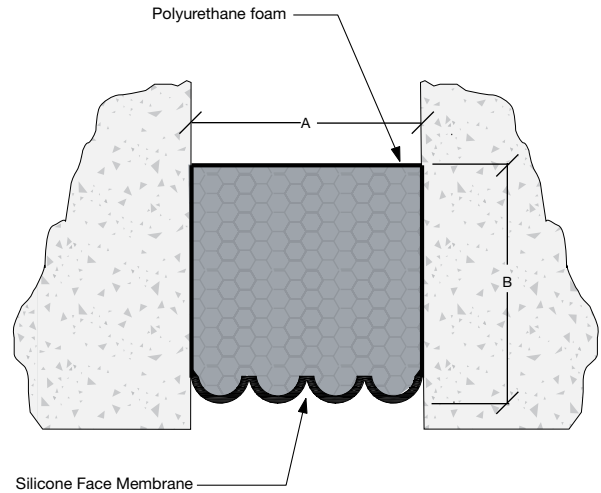

Wabo® Seismic WeatherSeal



Wall-to-Wall

Model #	Joint Opening "A"						System Depth "B"	
	Min		Max		Total		in	mm
	in	mm	in	mm	in	mm		
SWS-100	0.50	13	1.50	38	1.00	25	1.50	38
SWS-150	0.75	19	2.25	57	1.50	38	2.00	51
SWS-200	1.00	25	3.00	76	2.00	51	2.00	51
SWS-250	1.25	32	3.75	95	2.50	64	2.00	51
SWS-300	1.50	38	4.50	114	3.00	76	3.00	76
SWS-350	1.75	44	5.25	133	3.50	89	3.00	76
SWS-400	2.00	51	6.00	152	4.00	102	4.00	102
SWS-500	2.50	64	7.50	191	5.00	127	4.00	102
SWS-600	3.00	76	9.00	229	6.00	152	4.00	102

Note: Other sizes are available. Contact WBA for details.

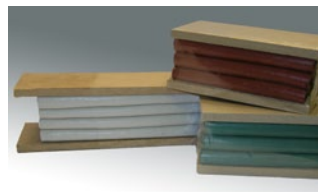

FEATURES

- Versatile movement +/-50%
- Ease of installation
- Colorable
- Pre-compressed

SWS

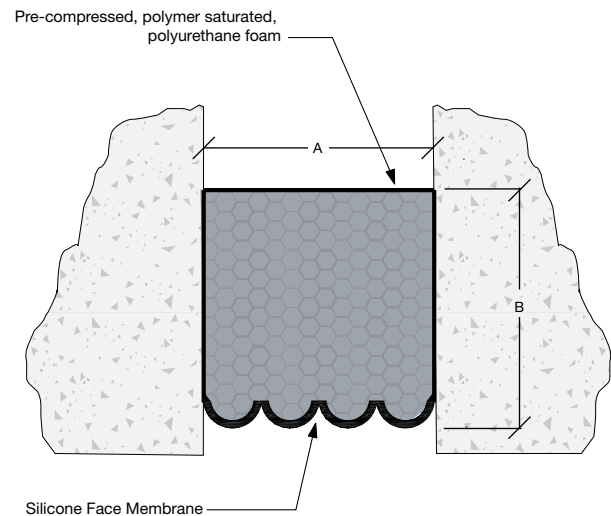

FEATURES

- Weather-tight sealing design
- Multi-directional / seismic movement
- Handles directional changes
- System width equal to opening
- Colorable, elastomeric seals
- Mechanical or epoxy anchor

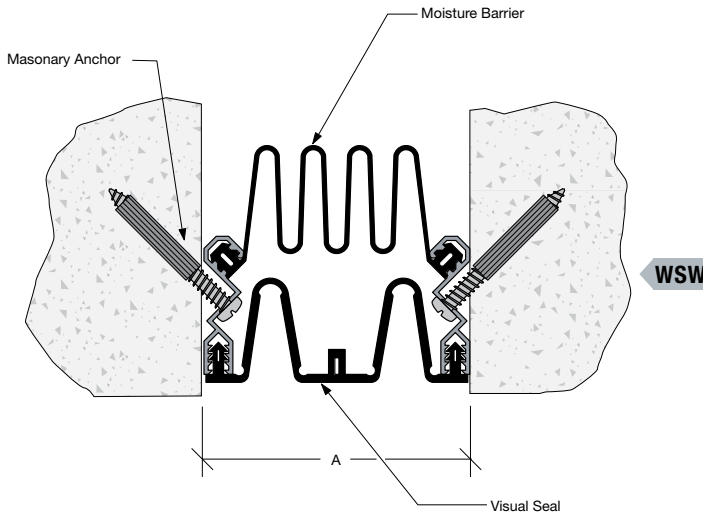
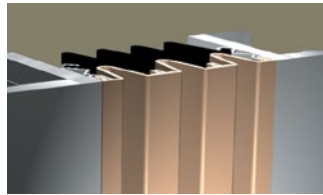

WSW

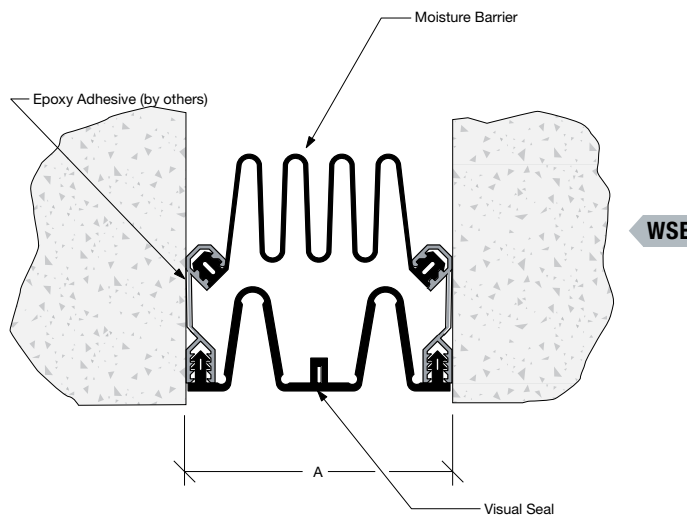

WSE

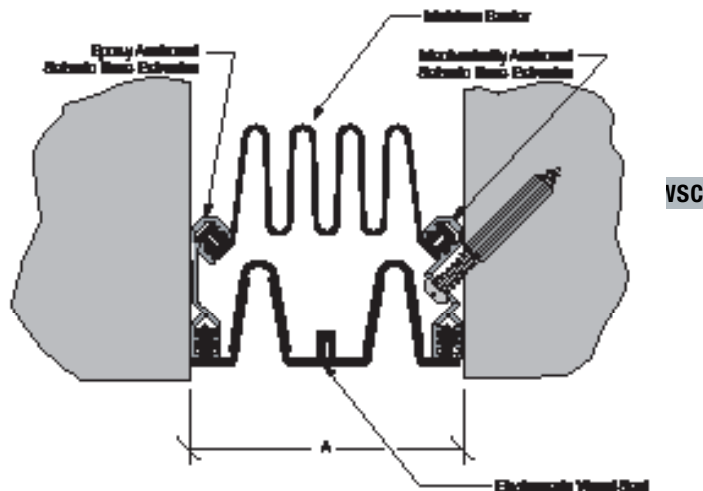

VSC

Wabo® WeatherSeam

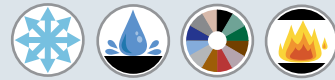

Wall-to-Wall

Model #	# Of Seals	Joint Opening "A"		Total Movement	
		in	mm	in	mm
WSW-200	1	2.00	51	2.63	67
WSW-300	1	3.00	76	5.13	130
WSW-400	1	4.00	102	4.75	121
WSW-500	1	5.00	127	6.75	171
WSW-600	1	6.00	152	9.50	241
WSW-800	2	8.00	203	9.63	245
WSW-1000	2	10.00	254	13.63	346
WSW-1200	2	12.00	305	19.13	486
WSW-900	3	9.00	229	15.38	391
WSW-1500	4	15.00	381	20.25	514
WSW-1600	3	18.00	457	19.00	483
WSW-1800	4	18.00	457	28.50	724
WSW-2000	4	20.00	508	27.00	686
WSW-2400	4	24.00	610	38.00	965

Note: Moisture barrier is included for exterior applications. Interior applications do not require moisture barrier. Specify with or without moisture barrier and application use.

Wall-to-Wall

Model #	# Of Seals	Joint Opening "A"		Total Movement	
		in	mm	in	mm
WSE-200	1	2.00	51	2.63	67
WSE-300	1	3.00	76	5.13	130
WSE-400	1	4.00	102	4.75	121
WSE-500	1	5.00	127	6.75	171
WSE-600	1	6.00	152	9.50	241

Note: Moisture barrier is included for exterior applications. Interior applications do not require moisture barrier. Specify with or without moisture barrier and application use.

Wall-to-Corner

Model #	# Of Seals	Joint Opening "A"		Total Movement	
		in	mm	in	mm
WSC-200	1	2.00	51	2.63	67
WSC-300	1	3.00	76	5.13	130
WSC-400	1	4.00	102	4.75	121
WSC-500	1	5.00	127	6.75	171
WSC-600	1	6.00	152	9.50	241

Note: Moisture barrier is included for exterior applications. Interior applications do not require moisture barrier. Specify with or without moisture barrier and application use.



Wabo® FlameGuard I

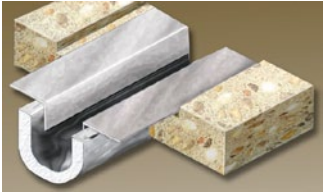

FEATURES

- Fire ratings to 4 hrs. for nominal openings up to 12 inches
- Meets the requirements of ASTM E-1399, ASTM E-119, ICBO ES AC30, CAN/ULC-S101
- Cycle tested
- Listed with ITS
- No caulks or sealants required against adjacent construction

Floor-to-Floor

Model #	Joint Opening		Total Movement	
	in	mm	in	mm
3 Hour Rating Horizontal Applications				
HFG-2.5-3	2.50	64	2.50	64
HFG-3-3	3.00	76	3.00	76
HFG-4-3	4.00	102	4.00	102
HFG-6-3	6.00	152	6.00	152
HFG-8-3	8.00	203	8.00	203
HFG-10-3	10.00	254	10.00	254
HFG-12-3	12.00	305	12.00	305
4 Hour Rating Horizontal Applications				
HFG-4-4	4.00	102	4.00	102
HFG-6-4	6.00	152	6.00	152
HFG-8-4	8.00	203	8.00	203
HFG-10-4	10.00	254	10.00	254
HFG-12-4	12.00	305	12.00	305

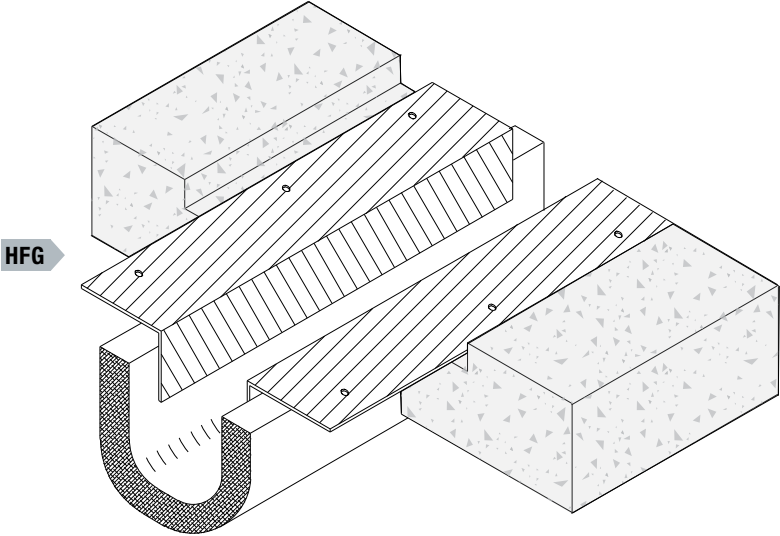

FEATURES

- Fire ratings to 4 hrs. for 2 inch joint openings
Fire ratings to 2 hrs. for joint opening up to 12 inches
- Meets the requirements of
UL-2079, ASTM E-1966, ICBO
ES AC30, CAN/ULC-S101
- Cycle tested
- Listed with ULC & UL

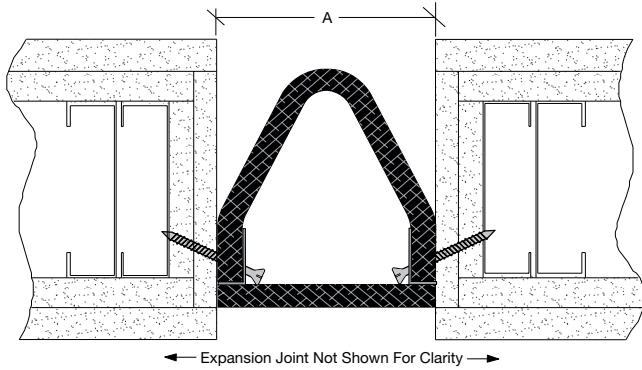
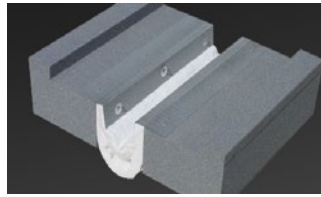

VFG

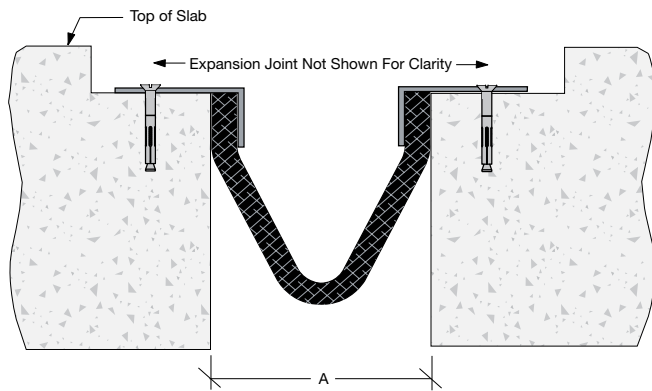

HFG

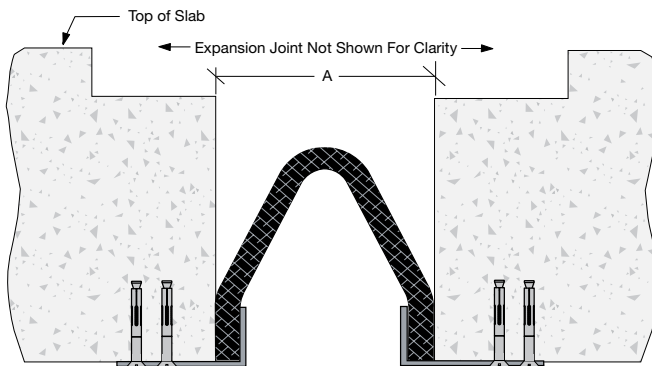

UFG

Wabo® FlameGuard II



Wall-to-Wall

Model #	Joint Opening "A"		Total Movement	
	in	mm	in	mm
1 Hour Rating Vertical Applications				
VFG-801	8.00	203	8.00	203
VFG-1001	10.00	254	10.00	254
VFG-1201	12.00	305	12.00	305
2 Hour Rating Vertical Applications				
VFG-202	2.00	51	2.00	51
VFG-402	4.00	102	4.00	102
VFG-602	6.00	152	6.00	152
VFG-802	8.00	203	8.00	203
VFG-1002	10.00	254	10.00	254
VFG-1202	12.00	305	12.00	305
VFG-1402	14.00	356	14.00	356
VFG-1602	16.00	406	16.00	406
VFG-1802	18.00	457	18.00	457
3 Hour Rating Vertical Application				
VFG-203	2.00	51	2.00	51

Floor-to-Floor

Model #	Joint Opening "A"		Total Movement	
	in	mm	in	mm
4 Hour Rating Horizontal Application				
HFG-204	2.00	51	2.00	51
1 Hour Rating Horizontal Applications				
HFG-401, 401C	4.00	102	4.00	102
HFG-601, 601C	6.00	152	6.00	152
HFG-801, 801C	8.00	203	8.00	187
HFG-1001, 1001C	10.00	254	10.00	254
HFG-1201, 1201C	12.00	305	12.00	305
2 Hour Rating Horizontal Applications				
HFG-402, 402C	4.00	102	4.00	102
HFG-602, 602C	6.00	152	6.00	152
HFG-802, 802C	8.00	203	8.00	203
HFG-1002, 1002C	10.00	254	10.00	254
HFG-1202, 1202C	12.00	305	12.00	305

Under Slab

Model #	Joint Opening "A"		Total Movement	
	in	mm	in	mm
2 Hour Rating Horizontal Applications				
UFG-402, 402C	4.00	102	4.00	102
UFG-602, 602C	6.00	152	6.00	152
UFG-802, 802C	8.00	203	8.00	203
UFG-1002, 1002C	10.00	254	10.00	254
UFG-1202, 1202C	12.00	305	12.00	305



Wabo® FireFlex



Wall-to-Wall

Model #	Joint Opening		Total Movement	
	in	mm	in	mm
2 Hour Horizontal Floor-to-Floor				
VFF-01-2	1.00	25	1.00	25
VFF-02-2	2.00	51	2.00	51
VFF-03-2	3.00	76	3.00	76
VFF-04-2	4.00	102	4.00	102
VFF-05-2	5.00	127	5.00	127
VFF-06-2	6.00	152	6.00	152
VFF-08-2	8.00	203	8.00	203
VFF-10-2	10.00	254	10.00	254
VFF-12-2	12.00	305	12.00	305
VFF-14-2	14.00	356	14.00	356
VFF-16-2	16.00	406	16.00	406
VFF-18-2	18.00	457	18.00 </td <td>457</td>	457
VFF-20-2	20.00	508	20.00	508

Floor-to-Floor

Model #	Joint Opening		Total Movement	
	in	mm	in	mm
2 Hour Horizontal Floor-to-Floor				
HFF-01-2	1.00	25	1.00	25
HFF-02-2	2.00	51	2.00	51
HFF-03-2	3.00	76	3.00	76
HFF-04-2	4.00	102	4.00	102
HFF-05-2	5.00	127	5.00	127
HFF-06-2	6.00	152	6.00	152
HFF-08-2	8.00	203	8.00	203
HFF-10-2	10.00	254	10.00	254
HFF-12-2	12.00	305	12.00	305
HFF-14-2	14.00	356	14.00	356
HFF-16-2	16.00	406	16.00	406
HFF-18-2	18.00	457	18.00	457
HFF-20-2	20.00	508	20.00	508

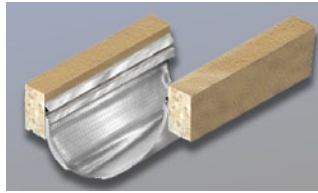

FEATURES

- Fire ratings to 2 hrs. for nominal openings up to 20 inches
- Meets UL-2079 and ICBO AC30
- Cycle tested for seismic lateral shear
- Listed with UL for class II & III movement
- No caulks or sealants required for installation

VFF

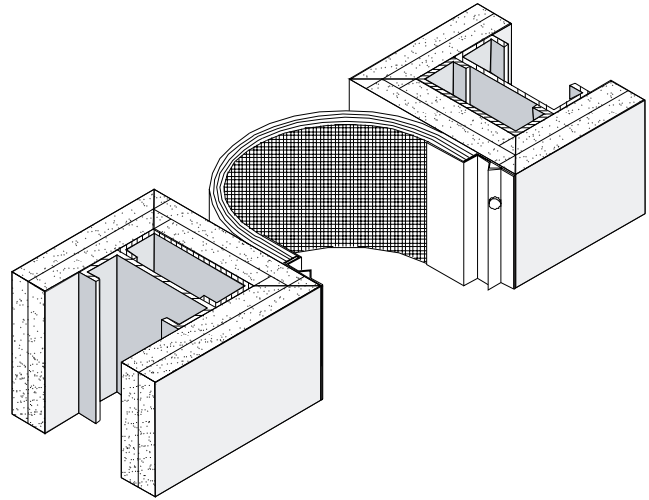

HFF

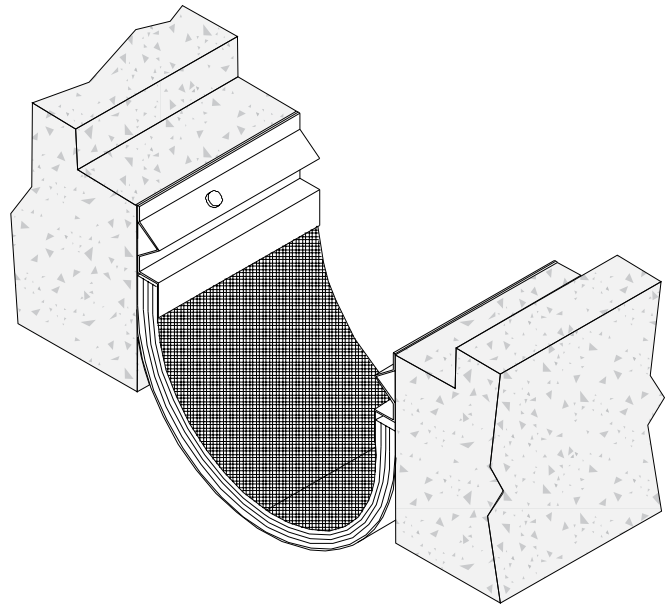

FEATURES

- Fire ratings to 3 hrs. for nominal openings up to 4 inches
- Meets the requirements of ASTM E-119, UL-263, CAN/ULC-S101, NFPA-251
- Listed with ITS
- No caulks or sealants required against adjacent construction
- No metal profiles utilized

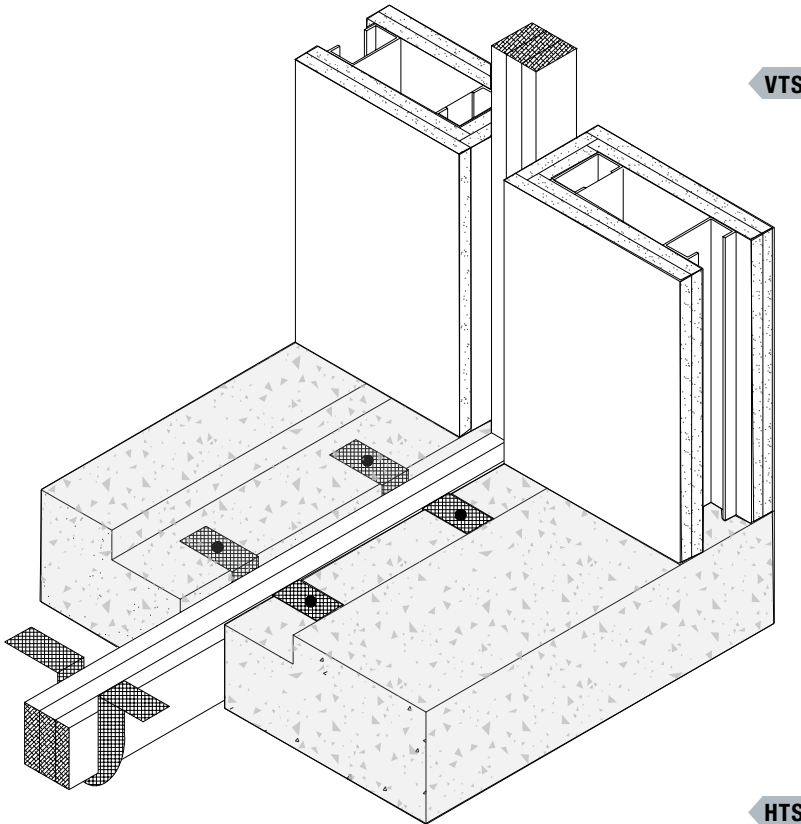
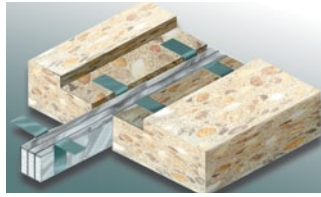

VTS

HTS

Wabo® ThermoShield



Wall-to-Wall

Model #	Joint Opening		Total Movement	
	in	mm	in	mm
1 & 2 Hour Rating Vertical Applications				
VTS-1	1.00	25	1.00	25
VTS-1.5	1.50	38	1.50	38
VTS-2	2.00	51	2.00	51
VTS-2.5	2.50	64	2.50	64
VTS-3	3.00	76	3.00	76
VTS-3.5	3.50	89	3.50	89
VTS-4	4.00	102	4.00	102

Floor-to-Floor

Model #	Joint Opening		Total Movement	
	in	mm	in	mm
1, 2 & 3 Hour Rating Horizontal Applications				
HTS-1	1.00	25	1.00	25
HTS-1.5	1.50	38	1.50	38
HTS-2	2.00	51	2.00	51
HTS-2.5	2.50	64	2.50	64
HTS-3	3.00	76	3.00	76
HTS-3.5	3.50	89	3.50	89
HTS-4	4.00	102	4.00	102

The Expansion Control Company.

Founded in 1950, Watson Bowman Acme (WBA) is the world wide leader and recognized innovator in the development and manufacture of expansion control systems for the construction industry. WBA has taken great strides in achieving production efficiencies and environmental stewardship through its formal American Institute of Steel Construction, ISO 9001:2008 and RC 14001 certifications. These certifications enhance the company's commitment and passion for excellence. WBA uses its expertise in the design and manufacture of quality expansion control systems to produce products that perform and last. Watson Bowman Acme is "The Expansion Control Company".

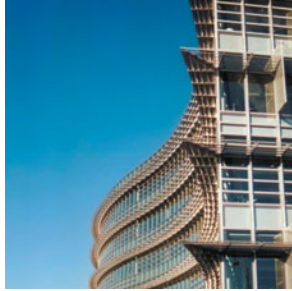

ARCHITECTURAL BUILDINGS



BRIDGE & HIGHWAY

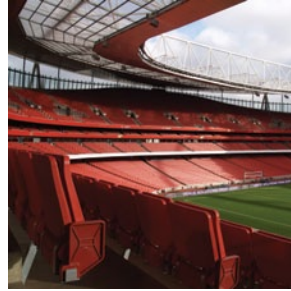

STADIUM STRUCTURES

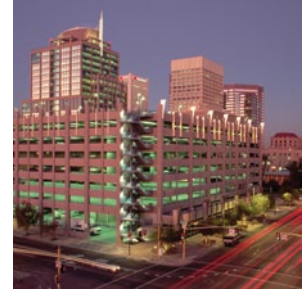

PARKING STRUCTURES

Technical Expertise

Engineers and owners who are charged with the responsibility of searching out every possible avenue to extend the life of their structures turn to Watson Bowman Acme with their specific needs. More than 60 years of practical experience and knowledge in the Expansion Control industry allows WBA to develop solutions and make recommendations for the right product choice for your application.

Innovation

Recognized as the industry leader in the development of expansion control systems, WBA has developed and manufactured products and solutions for some of the worlds' most unique and complex projects. Offering the broadest range of products and services in the construction industry, we are the only company servicing the Bridge and Highway, Architectural, Parking and Stadium markets. We have a fully qualified team of professional engineers and designers backed by strong relationships with national testing labs and universities. WBA has long been recognized for its innovation. We will continue to build on that reputation for years to come.

Custom Solutions

WBA provides more than just technical expertise, we supply solutions that make good sense. We offer a growing range of high performance Wabo® brand products and systems to provide long lasting solutions to difficult repair problems. We are fully resourced to deliver results and exceed the expectations of our customers, a standard of service they should expect.

Quality

WBA is dedicated in providing the highest quality products and services to our customers with a commitment for continuous improvement. Increased quality in service and manufacturing will ensure positive results for your project. Our professional operations team employs the principles of lean manufacturing, and enterprise resource planning tools, all supported by our formal ISO 9001:2008, RC14001 and AISC quality management systems.

wbacorp.com

We are continually improving the Watson Bowman Acme website, enhancing your ability to easily navigate through our products and services. WBA has evolved over the years, but one priority has remained the same: to provide you with the accurate information you need, when you need it.



Watson Bowman Acme Corp.
95 Pineview Drive Amherst, NY 14228
phone 716.691.7566
fax 716.691.9239
wbacorp.com



The Chemical Company

© 2014 Watson Bowman Acme Corp.
All rights reserved / Printed in USA
Arch-intrm-07.07.14